

SP601 Hardware User Guide

UG518 (v1.1) August 19, 2009



Xilinx is disclosing this user guide, manual, release note, and/or specification (the "Documentation") to you solely for use in the development of designs to operate with Xilinx hardware devices. You may not reproduce, distribute, republish, download, display, post, or transmit the Documentation in any form or by any means including, but not limited to, electronic, mechanical, photocopying, recording, or otherwise, without the prior written consent of Xilinx. Xilinx expressly disclaims any liability arising out of your use of the Documentation. Xilinx reserves the right, at its sole discretion, to change the Documentation without notice at any time. Xilinx assumes no obligation to correct any errors contained in the Documentation, or to advise you of any corrections or updates. Xilinx expressly disclaims any liability in connection with technical support or assistance that may be provided to you in connection with the Information.

THE DOCUMENTATION IS DISCLOSED TO YOU "AS-IS" WITH NO WARRANTY OF ANY KIND. XILINX MAKES NO OTHER WARRANTIES, WHETHER EXPRESS, IMPLIED, OR STATUTORY, REGARDING THE DOCUMENTATION, INCLUDING ANY WARRANTIES OF MERCHANTABILITY, FITNESS FOR A PARTICULAR PURPOSE, OR NONINFRINGEMENT OF THIRD-PARTY RIGHTS. IN NO EVENT WILL XILINX BE LIABLE FOR ANY CONSEQUENTIAL, INDIRECT, EXEMPLARY, SPECIAL, OR INCIDENTAL DAMAGES, INCLUDING ANY LOSS OF DATA OR LOST PROFITS, ARISING FROM YOUR USE OF THE DOCUMENTATION.

© 2009 Xilinx, Inc. XILINX, the Xilinx logo, Virtex, Spartan, ISE, and other designated brands included herein are trademarks of Xilinx in the United States and other countries. All other trademarks are the property of their respective owners.

Revision History

The following table shows the revision history for this document.

Date	Version	Revision
07/15/2009	1.0	Initial Xilinx release.
08/19/2009	1.1	<ul style="list-style-type: none">• Added Appendix C, "VITA 57.1 FMC Connections."• Updated Figure 1-18 and Figure 1-32.• Updated Table 1-4, Table 1-17, and Table 1-20.• Added introductory paragraph to Appendix D, "SP601 Master UCF."• Miscellaneous typographical edits and new user guide template.

Table of Contents

Preface: About This Guide

Guide Contents	7
Additional Resources	7
Conventions	7
Typographical	7
Online Document	8

Chapter 1: SP601 Evaluation Board

Overview	9
Additional Information	9
Features	10
Block Diagram	11
Related Xilinx Documents	11
Detailed Description	12
1. Spartan-6 XC6SLX16-2CSG324 FPGA	13
Configuration	13
I/O Voltage Rails	13
2. 128 MB DDR2 Component Memory	14
3. SPI x4 Flash	18
4. Linear Flash BPI	20
5. 10/100/1000 Tri-Speed Ethernet PHY	23
6. USB-to-UART Bridge	25
7. IIC Bus	26
8-Kb NV Memory	27
8. Clock Generation	27
Oscillator (Differential)	27
Oscillator Socket (Single-Ended, 2.5V or 3.3V)	28
SMA Connectors (Differential)	28
9. VITA 57.1 FMC-LPC Connector	28
10. Status LEDs	32
11. FPGA Awake LED and Suspend Jumper	33
12. FPGA INIT and DONE LEDs	34
13. User I/O	35
14. FPGA_PROG_B Pushbutton Switch	40
Power Management	40
AC Adapter and 5V Input Power Jack/Switch	40
Onboard Power Supplies	40
Configuration Options	42
JTAG Configuration	42

Appendix A: References

Appendix B: Default Jumper and Switch Settings

Appendix C: VITA 57.1 FMC Connections

Appendix D: SP601 Master UCF

About This Guide

This manual accompanies the Spartan®-6 FPGA SP601 Evaluation Board and contains information about the SP601 hardware and software tools.

Guide Contents

This manual contains the following chapters:

- [Chapter 1, “SP601 Evaluation Board,”](#) provides an overview of the embedded development board and details the components and features of the SP601 board.
- [Appendix A, “References.”](#)
- [Appendix B, “Default Jumper and Switch Settings.”](#)
- [Appendix D, “SP601 Master UCF.”](#)

Additional Resources

To search the database of silicon and software questions and answers, or to create a technical support case in WebCase, see the Xilinx website at: <http://www.xilinx.com/support>.

Conventions

This document uses the following conventions. An example illustrates each convention.

Typographical

The following typographical conventions are used in this document:

Convention	Meaning or Use	Example
Courier font	Messages, prompts, and program files that the system displays	<code>speed grade: - 100</code>
Courier bold	Literal commands that you enter in a syntactical statement	<code>ngdbuild design_name</code>
Helvetica bold	Commands that you select from a menu	File → Open
	Keyboard shortcuts	Ctrl+C

Convention	Meaning or Use	Example
<i>Italic font</i>	Variables in a syntax statement for which you must supply values	<code>ngdbuild design_name</code>
	References to other manuals	See the <i>User Guide</i> for more information.
	Emphasis in text	If a wire is drawn so that it overlaps the pin of a symbol, the two nets are <i>not</i> connected.
Dark Shading	Items that are not supported or reserved	This feature is not supported
Square brackets []	An optional entry or parameter. However, in bus specifications, such as <code>bus [7:0]</code> , they are required.	<code>ngdbuild [option_name] design_name</code>
Braces { }	A list of items from which you must choose one or more	<code>lowpwr = {on off}</code>
Vertical bar	Separates items in a list of choices	<code>lowpwr = {on off}</code>
Angle brackets < >	User-defined variable or in code samples	<directory name>
Vertical ellipsis .	Repetitive material that has been omitted	IOB #1: Name = QOUT' IOB #2: Name = CLKIN' . . .
Horizontal ellipsis ...	Repetitive material that has been omitted	<code>allow block block_name loc1 loc2 ... locn;</code>
Notations	The prefix '0x' or the suffix 'h' indicate hexadecimal notation	A read of address 0x00112975 returned 45524943h.
	An '_n' means the signal is active low	<code>usr_teof_n</code> is active low.

Online Document

The following conventions are used in this document:

Convention	Meaning or Use	Example
Blue text	Cross-reference link to a location in the current document	See the section " Additional Resources " for details. Refer to " Title Formats " in Chapter 1 for details.
Blue, underlined text	Hyperlink to a website (URL)	Go to http://www.xilinx.com for the latest speed files.

SP601 Evaluation Board

Overview

The SP601 board enables hardware and software developers to create or evaluate designs targeting the Spartan®-6 XC6SLX16-2CSG324 FPGA.

The SP601 provides board features for evaluating the Spartan-6 family that are common to most entry-level development environments. Some commonly used features include a DDR2 memory controller, a parallel linear flash, a tri-mode Ethernet PHY, general-purpose I/O (GPIO), and a UART. Additional functionality can be added through the VITA 57.1.1 expansion connector. “Features,” page 10 provides a general listing of the board features with details provided in “Detailed Description,” page 12.

Additional Information

Additional information and support material is located at:

- <http://www.xilinx.com/sp601>

This information includes:

- Current version of this user guide in PDF format
- Example design files for demonstration of Spartan-6 FPGA features and technology
- Demonstration hardware and software configuration files for the SP601 linear and SPI memory devices
- Reference Design Files
- Schematics in PDF format and DxDesigner schematic format
- Bill of materials (BOM)
- Printed-circuit board (PCB) layout in Allegro PCB format
- Gerber files for the PCB (Many free or shareware Gerber file viewers are available on the internet for viewing and printing these files.)
- Additional documentation, errata, frequently asked questions, and the latest news

For information about the Spartan-6 family of FPGA devices, including product highlights, data sheets, user guides, and application notes, see the Spartan-6 FPGA website at <http://www.xilinx.com/support/documentation/spartan-6.htm>.

Features

The SP601 board provides the following features:

- 1. Spartan-6 XC6SLX16-2CSG324 FPGA
- 2. 128 MB DDR2 Component Memory
- 3. SPI x4 Flash
- 4. Linear Flash BPI
- 5. 10/100/1000 Tri-Speed Ethernet PHY
- 7. IIC Bus
 - ◆ 8Kb NV memory
 - ◆ External access 2-pin header
 - ◆ VITA 57.1 FMC-LPC connector
- 8. Clock Generation
 - ◆ Oscillator (Differential)
 - ◆ Oscillator Socket (Single-Ended, 2.5V or 3.3V)
- SMA Connectors (Differential)
- 9. VITA 57.1 FMC-LPC Connector
- 10. Status LEDs
 - ◆ FPGA_AWAKE
 - ◆ INIT
 - ◆ DONE
- 13. User I/O
 - ◆ User LEDs
 - ◆ User DIP switch
 - ◆ User pushbuttons
 - ◆ GPIO male pin header
- 14. FPGA_PROG_B Pushbutton Switch
- Configuration Options
 - ◆ 3. SPI x4 Flash (both onboard and off-board)
 - ◆ 4. Linear Flash BPI
 - ◆ JTAG Configuration
- Power Management - AC Adapter and 5V Input Power Jack/Switch, Onboard Power Supplies

Block Diagram

Figure 1-1 shows a high-level block diagram of the SP601 and its peripherals.

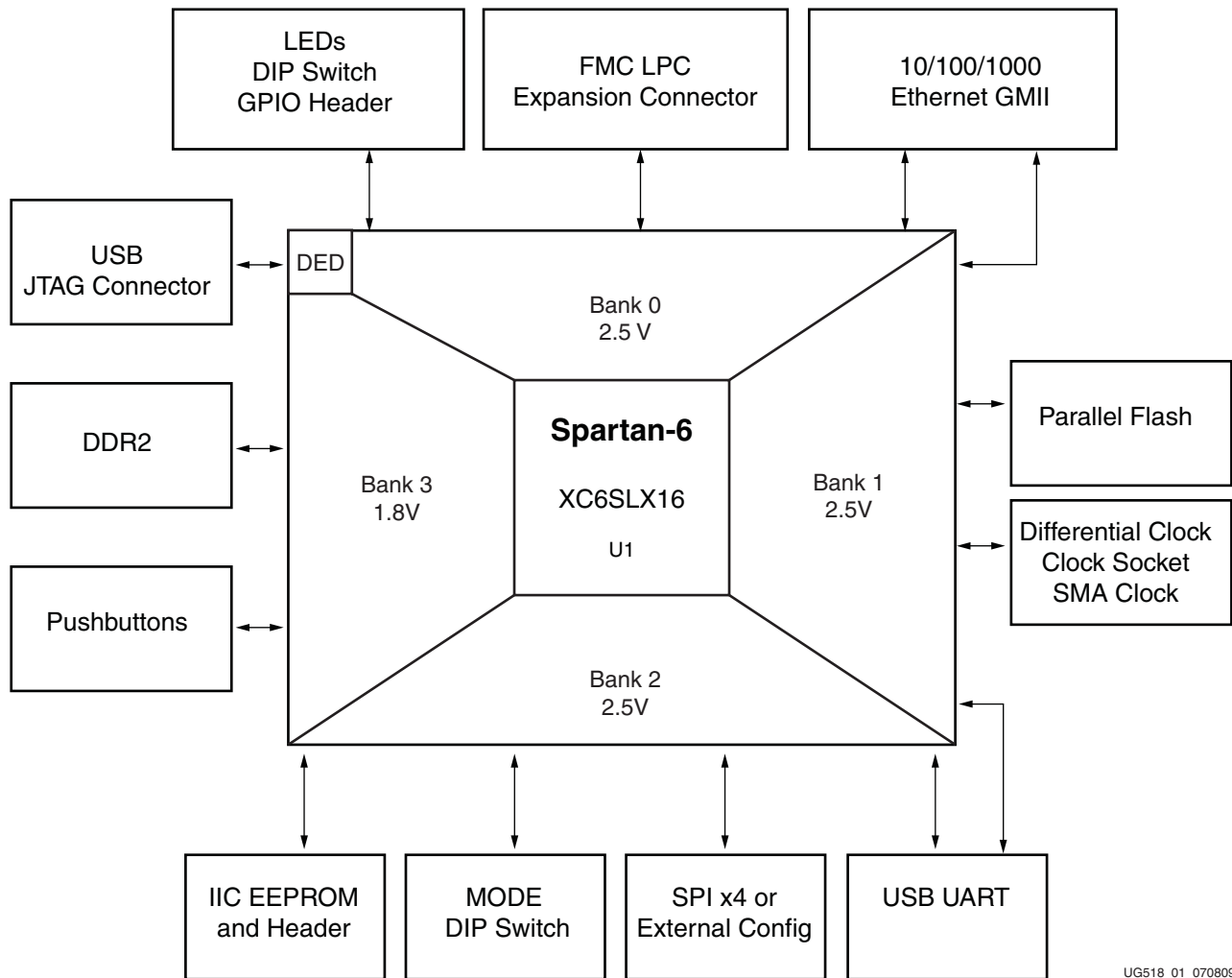

UG518_01_070809

Figure 1-1: SP601 Features and Banking

Related Xilinx Documents

Prior to using the SP601 Evaluation Board, users should be familiar with Xilinx resources. See the following locations for additional documentation on Xilinx tools and solutions:

- ISE: www.xilinx.com/ise
- Answer Browser: www.xilinx.com/support
- Intellectual Property: www.xilinx.com/ipcenter

Detailed Description

Figure 1-2 shows a board photo with numbered features corresponding to Table 1-1 and the section headings in this document.

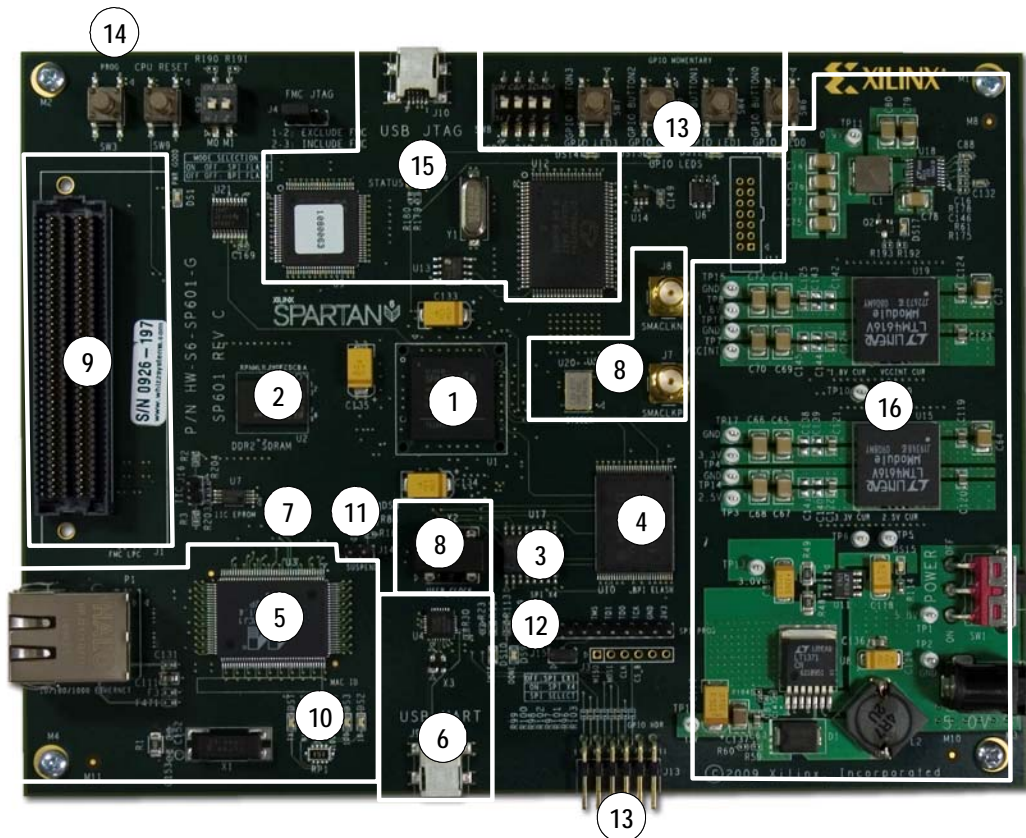

Figure 1-2: SP601 Board Photo

The numbered features in Figure 1-2 correlate to the features and notes listed in Table 1-1.

Table 1-1: SP601 Features

Number	Feature	Notes	Schematic Page
1	Spartan-6 FPGA	XC6SLX16-2CSG324	
2	DDR2 Component	Hard memory controller w/ OCT	5
3	SPI x4 Flash and Headers	SPI select and External Headers	8
4	Linear Flash BPI	StrataFlash 8-bit (J3 device), 3 pins shared w/ SPI x4	8
5	10/100/1000 Ethernet PHY	GMII Marvell Alaska PHY	7
6	RS232 UART (USB Bridge)	Uses CP2103 Serial-to-USB connection	10
7	IIC	Goes to Header and VITA 57.1 FMC	10
8	Clock, socket, SMA	Differential, Single-Ended, Differential	9

Table 1-1: SP601 Features (Cont'd)

Number	Feature	Notes	Schematic Page
9	VITA 57.1 FMC-LPC connector	LVDS signals, clocks, PRSNT	6
10	LEDs	Ethernet PHY Status	7
11	LED, Header	FPGA Awake LED, Suspend Header	8
12	LEDs	FPGA INIT, DONE	9
13	LED	User I/O (active-High)	9
	DIP Switch	User I/O (active-High)	9
	Pushbutton	User I/O, CPU_RESET (active-High)	9
	12-pin (8 I/O) Header	6 pins x 2 male header with 8 I/Os (active-High)	10
14	Pushbutton	FPGA_PROG_B	9
15	USB JTAG	Cypress USB to JTAG download cable logic	14, 15
16	Onboard Power	Power Management	11,12,13

1. Spartan-6 XC6SLX16-2CSG324 FPGA

A Xilinx Spartan-6 XC6SLX16-2CSG324 FPGA is installed on the Embedded Development Board.

Configuration

The SP601 supports configuration in the following modes:

- Master SPI x4
- Master SPI x4 with off-board device
- BPI
- JTAG (using the included USB-A to Mini-B cable)

For details on configuring the FPGA, see [“Configuration Options.”](#)

I/O Voltage Rails

There are four available banks on the LX16-CS324 device. Banks 0, 1, and 2 are connected for 2.5V I/O. Bank 3 is used for the 1.8V DDR2 component memory interface of Spartan-6 FPGA’s hard memory controller. The voltage applied to the FPGA I/O banks used by the SP601 board is summarized in [Table 1-2](#).

Table 1-2: I/O Voltage Rail of FPGA Banks

FPGA Bank	I/O Voltage Rail
0	2.5V
1	2.5V

Table 1-2: I/O Voltage Rail of FPGA Banks (Cont'd)

FPGA Bank	I/O Voltage Rail
2	2.5V
3	1.8V

References

See the Xilinx Spartan-6 FPGA documentation for more information at <http://www.xilinx.com/support/documentation/spartan-6.htm>.

2. 128 MB DDR2 Component Memory

There are 128 MB of DDR2 memory available on the SP601 board. A 1-Gb Elpida EDE1116ACBG (84-ball) DDR2 memory component is accessible through Bank 3 of the LX16 device. The Spartan-6 FPGA hard memory controller is used for data transfer across the DDR2 memory interface's 16-bit data path using SSTL18 signaling. The maximum data rate supported is 800 Mb/s with a memory clock running at 400 MHz. Signal integrity is maintained through DDR2 resistor terminations and memory on-die terminations (ODT), as shown in Table 1-3 and Table 1-4.

Table 1-3: Termination Resistor Requirements

Signal Name	Board Termination	On-Die Termination
DDR2_A[14:0]	49.9 ohms to V_{TT}	
DDR2_BA[2:0]	49.9 ohms to V_{TT}	
DDR2_RAS_N	49.9 ohms to V_{TT}	
DDR2_CAS_N	49.9 ohms to V_{TT}	
DDR2_WE_N	49.9 ohms to V_{TT}	
DDR2_CS_N	100 ohms to GND	
DDR2_CKE	4.7K ohms to GND	
DDR2_ODT	4.7K ohms to GND	
DDR2_DQ[15:0]		ODT
DDR2_UDQS[P,N], DDR2_LDQS[P,N]		ODT
DDR2_UDM, DDR2_LDM		ODT
DDR2_CK[P,N]	100 ohm differential at memory component	

Notes:

- Nominal value of V_{TT} for DDR2 interface is 0.9V.

Table 1-4: FPGA On-Chip (OCT) Termination External Resistor Requirements

FPGA U1 Pin	FPGA Pin Number	Board Connection for OCT
ZIO	L6	No Connect
RZQ	C2	100 ohms to GROUND

Table 1-5 shows the connections and pin numbers for the DDR2 Component Memory.

Table 1-5: **DDR2 Component Memory Connections**

FPGA U1	Schematic Netname	Memory U2	
		Pin Number	Name
J7	DDR2_A0	M8	A0
J6	DDR2_A1	M3	A1
H5	DDR2_A2	M7	A2
L7	DDR2_A3	N2	A3
F3	DDR2_A4	N8	A4
H4	DDR2_A5	N3	A5
H3	DDR2_A6	N7	A6
H6	DDR2_A7	P2	A7
D2	DDR2_A8	P8	A8
D1	DDR2_A9	P3	A9
F4	DDR2_A10	M2	A10
D3	DDR2_A11	P7	A11
G6	DDR2_A12	R2	A12
L2	DDR2_DQ0	G8	DQ0
L1	DDR2_DQ1	G2	DQ1
K2	DDR2_DQ2	H7	DQ2
K1	DDR2_DQ3	H3	DQ3
H2	DDR2_DQ4	H1	DQ4
H1	DDR2_DQ5	H9	DQ5
J3	DDR2_DQ6	F1	DQ6
J1	DDR2_DQ7	F9	DQ7
M3	DDR2_DQ8	C8	DQ8
M1	DDR2_DQ9	C2	DQ9
N2	DDR2_DQ10	D7	DQ10
N1	DDR2_DQ11	D3	DQ11
T2	DDR2_DQ12	D1	DQ12
T1	DDR2_DQ13	D9	DQ13
U2	DDR2_DQ14	B1	DQ14
U1	DDR2_DQ15	B9	DQ15

Table 1-5: DDR2 Component Memory Connections (Cont'd)

FPGA U1	Schematic Netname	Memory U2	
		Pin Number	Name
F2	DDR2_BA0	L2	BA0
F1	DDR2_BA1	L3	BA1
E1	DDR2_BA2	L1	BA2
E3	DDR2_WE_B	K3	WE
L5	DDR2_RAS_B	K7	RAS
K5	DDR2_CAS_B	L7	CAS
K6	DDR2_ODT	K9	ODT
G3	DDR2_CLK_P	J8	CK
G1	DDR2_CLK_N	K8	CK
H7	DDR2_CKE	K2	CKE
L4	DDR2_LDQS_P	F7	LDQS
L3	DDR2_LDQS_N	E8	LDQS
P2	DDR2_UDQS_P	B7	UDQS
P1	DDR2_UDQS_N	A8	UDQS
K3	DDR2_LDM	F3	LDM
K4	DDR2_UDM	B3	UDM

Figure 1-3 provides the user constraints file (UCF) for the DDR2 SDRAM address pins, including the I/O pin assignment and the I/O standard used.

```

NET "DDR2_A12" LOC = "G6" ; | IOSTANDARD = SSTL18_II ;
NET "DDR2_A11" LOC = "D3" ; | IOSTANDARD = SSTL18_II ;
NET "DDR2_A10" LOC = "F4" ; | IOSTANDARD = SSTL18_II ;
NET "DDR2_A9" LOC = "D1" ; | IOSTANDARD = SSTL18_II ;
NET "DDR2_A8" LOC = "D2" ; | IOSTANDARD = SSTL18_II ;
NET "DDR2_A7" LOC = "H6" ; | IOSTANDARD = SSTL18_II ;
NET "DDR2_A6" LOC = "H3" ; | IOSTANDARD = SSTL18_II ;
NET "DDR2_A5" LOC = "H4" ; | IOSTANDARD = SSTL18_II ;
NET "DDR2_A4" LOC = "F3" ; | IOSTANDARD = SSTL18_II ;
NET "DDR2_A3" LOC = "L7" ; | IOSTANDARD = SSTL18_II ;
NET "DDR2_A2" LOC = "H5" ; | IOSTANDARD = SSTL18_II ;
NET "DDR2_A1" LOC = "J6" ; | IOSTANDARD = SSTL18_II ;
NET "DDR2_A0" LOC = "J7" ; | IOSTANDARD = SSTL18_II ;

```

Figure 1-3: UCF Location Constraints for DDR2 SDRAM Address Inputs

Figure 1-4 provides the UCF constraints for the DDR2 SDRAM data pins, including the I/O pin assignment and I/O standard used.

```
NET "DDR2_DQ15" LOC ="U1" ; | IOSTANDARD = SSTL18_II ;
NET "DDR2_DQ14" LOC ="U2" ; | IOSTANDARD = SSTL18_II ;
NET "DDR2_DQ13" LOC ="T1" ; | IOSTANDARD = SSTL18_II ;
NET "DDR2_DQ12" LOC ="T2" ; | IOSTANDARD = SSTL18_II ;
NET "DDR2_DQ11" LOC ="N1" ; | IOSTANDARD = SSTL18_II ;
NET "DDR2_DQ10" LOC ="N2" ; | IOSTANDARD = SSTL18_II ;
NET "DDR2_DQ9" LOC ="M1" ; | IOSTANDARD = SSTL18_II ;
NET "DDR2_DQ8" LOC ="M3" ; | IOSTANDARD = SSTL18_II ;
NET "DDR2_DQ7" LOC ="J1" ; | IOSTANDARD = SSTL18_II ;
NET "DDR2_DQ6" LOC ="J3" ; | IOSTANDARD = SSTL18_II ;
NET "DDR2_DQ5" LOC ="H1" ; | IOSTANDARD = SSTL18_II ;
NET "DDR2_DQ4" LOC ="H2" ; | IOSTANDARD = SSTL18_II ;
NET "DDR2_DQ3" LOC ="K1" ; | IOSTANDARD = SSTL18_II ;
NET "DDR2_DQ2" LOC ="K2" ; | IOSTANDARD = SSTL18_II ;
NET "DDR2_DQ1" LOC ="L1" ; | IOSTANDARD = SSTL18_II ;
NET "DDR2_DQ0" LOC ="L2" ; | IOSTANDARD = SSTL18_II ;
```

Figure 1-4: UCF Location Constraints for DDR2 SDRAM Data I/O Pins

Figure 1-5 provides the UCF constraints for the DDR2 SDRAM control pins, including the I/O pin assignment and the I/O standard used.

```
NET "DDR2_WE_B" LOC ="E3" ; | IOSTANDARD = SSTL18_II ;
NET "DDR2_UDQS_P" LOC ="P2" ; | IOSTANDARD = SSTL18_II ;
NET "DDR2_UDQS_N" LOC ="P1" ; | IOSTANDARD = SSTL18_II ;
NET "DDR2_UDM" LOC ="K4" ; | IOSTANDARD = SSTL18_II ;
NET "DDR2_RAS_B" LOC ="L5" ; | IOSTANDARD = SSTL18_II ;
NET "DDR2_ODT" LOC ="K6" ; | IOSTANDARD = SSTL18_II ;
NET "DDR2_LDQS_P" LOC ="L4" ; | IOSTANDARD = SSTL18_II ;
NET "DDR2_LDQS_N" LOC ="L3" ; | IOSTANDARD = SSTL18_II ;
NET "DDR2_LDM" LOC ="K3" ; | IOSTANDARD = SSTL18_II ;
NET "DDR2_CLK_P" LOC ="G3" ; | IOSTANDARD = SSTL18_II ;
NET "DDR2_CLK_N" LOC ="G1" ; | IOSTANDARD = SSTL18_II ;
NET "DDR2_CKE" LOC ="H7" ; | IOSTANDARD = SSTL18_II ;
NET "DDR2_CAS_B" LOC ="K5" ; | IOSTANDARD = SSTL18_II ;
NET "DDR2_BA2" LOC ="E1" ; | IOSTANDARD = SSTL18_II ;
NET "DDR2_BA1" LOC ="F1" ; | IOSTANDARD = SSTL18_II ;
NET "DDR2_BA0" LOC ="F2" ; | IOSTANDARD = SSTL18_II ;
```

Figure 1-5: UCF Location Constraints for DDR2 SDRAM Control Pins

References

See the Elpida DDR2 specifications for more information at <http://www.elpida.com/en/products/details/EDE1116ACBG.html>.

Also, see the Spartan-6 FPGA embedded hard memory controller block user guide at http://www.xilinx.com/support/documentation/user_guides/ug388.pdf.

3. SPI x4 Flash

The Xilinx Spartan-6 FPGA hosts a SPI interface which is visible to the Xilinx iMPACT configuration tool. The SPI memory device operates at 3.0V; the Spartan-6 FPGA I/Os are 3.3V tolerant and provide electrically compatible logic levels to directly access the SPI flash through a 2.5V bank. The XC6SLX16-2CSG324 is a master device when accessing an external SPI flash memory device.

The SP601 SPI interface has two parallel connected configuration options (see [Figure 1-7](#)): an SPI X4 (Winbond W25Q64VFIG) 64-Mb flash memory device and a flash programming header (J12). J12 supports a user-defined SPI mezzanine board. The SPI configuration source is selected via SPI select jumper J15. For details on configuring the FPGA, see [“Configuration Options.”](#)

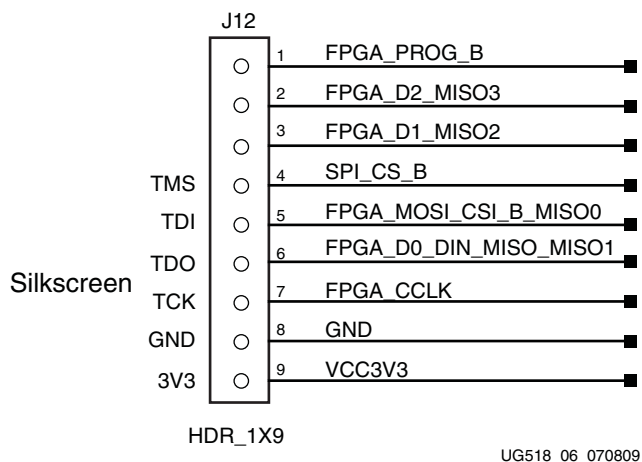

Figure 1-6: J12 SPI Flash Programming Header

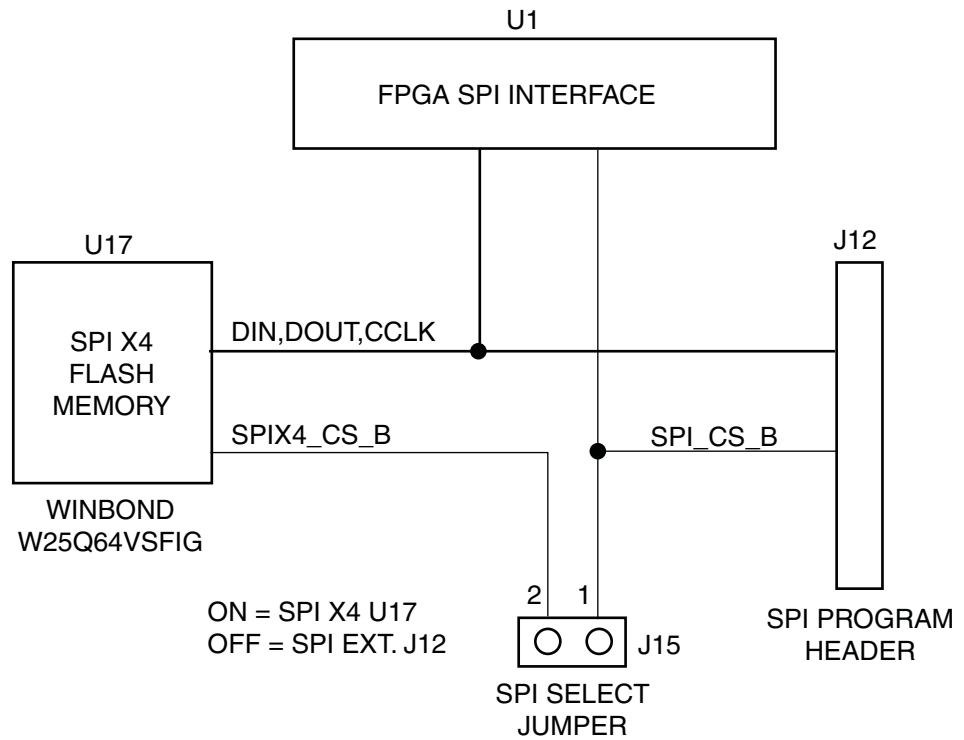

Figure 1-7: SPI Flash Interface Topology

Table 1-6: SPI x4 Memory Connections

FPGA U1 Pin	Schematic Netname	SPI MEM U17		SPI HDR J12	
		Pin #	Pin Name	Pin #	Pin Name
V2	FPGA_PROG_B			1	
V14	FPGA_D2_MISO3	1	IO3_HOLD_B	2	
T14	FPGA_D1_MISO2_R	9	IO2_WP_B	3	
V3	SPI_CS_B			4	TMS
T13	FPGA_MOSI_CSI_B_MISO0	15	DIN	5	TDI
R13	FPGA_D0_DIN_MISO_MISO1	8	IO1_DOUT	6	TDO
R15	FPGA_CCLK	16	CLK	7	TCK
				8	GND
				9	VCC3V3
J15.2	SPIX4_CS_B	7	CS_B		

Figure 1-8 provides the UCF constraints for the SPI serial flash PROM.

```

NET "FPGA_D2_MISO3"           LOC = "V14";
NET "SPI_CS_B"                LOC = "V3";
NET "FPGA_D0_DIN_MISO_MISO1" LOC = "R13";
NET "FPGA_D1_MISO2"          LOC = "T14";
NET "FPGA_MOSI_CSI_B_MISO0"  LOC = "T13";
NET "FPGA_CCLK"              LOC = "R15";

```

Figure 1-8: UCF Location Constraints for BPI Flash Connections

References

See the Winbond Serial Flash specifications for more information at <http://www.winbond-usa.com/hq/enu/ProductAndSales/ProductLines/FlashMemory/SerialFlash/W25X64.htm>.

See the XPS Serial Peripheral Interface specification for more information at http://www.xilinx.com/support/documentation/ip_documentation/xps_spi.pdf.

4. Linear Flash BPI

An 8-bit (16 MB) Numonyx linear flash memory (TE 28F128J3D-75) (J3D type) is used to provide non-volatile bitstream, code, and data storage. The J3D devices operate at 3.0V; the Spartan-6 FPGA I/Os are 3.3V tolerant and provide electrically compatible logic levels to directly access the linear flash BPI through a 2.5V bank. For details on configuring the FPGA, see “[Configuration Options](#).”

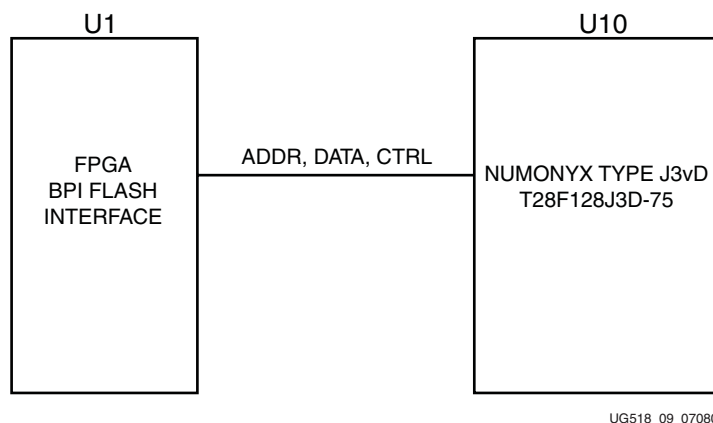

Figure 1-9: Linear Flash BPI Interface

Table 1-7: BPI Memory Connections

FPGA U1 Pin	Schematic Netname	BPI Memory U10	
		Pin Number	Pin
K18	FLASH_A0	32	A0
K17	FLASH_A1	28	A1
J18	FLASH_A2	27	A2
J16	FLASH_A3	26	A3
G18	FLASH_A4	25	A4
G16	FLASH_A5	24	A5

Table 1-7: BPI Memory Connections (Cont'd)

FPGA U1 Pin	Schematic Netname	BPI Memory U10	
		Pin Number	Pin
H16	FLASH_A6	23	A6
H15	FLASH_A7	22	A7
H14	FLASH_A8	20	A8
H13	FLASH_A9	19	A9
F18	FLASH_A10	18	A10
F17	FLASH_A11	17	A11
K13	FLASH_A12	13	A12
K12	FLASH_A13	12	A13
E18	FLASH_A14	11	A14
E16	FLASH_A15	10	A15
G13	FLASH_A16	8	A16
H12	FLASH_A17	7	A17
D18	FLASH_A18	6	A18
D17	FLASH_A19	5	A19
G14	FLASH_A20	4	A20
F14	FLASH_A21	3	A21
C18	FLASH_A22	1	A22
C17	FLASH_A23	30	A23
F16	FLASH_A24	56	A24
R13	FPGA_D0_DIN_MISO_MISO1	33	DQ0
T14	FPGA_D1_MISO2	35	DQ1
V14	FPGA_D2_MISO3	38	DQ2
U5	FLASH_D3	40	DQ3
V5	FLASH_D4	44	DQ4
R3	FLASH_D5	46	DQ5
T3	FLASH_D6	49	DQ6
R5	FLASH_D7	51	DQ7
M16	FLASH_WE_B	55	WE_B
L18	FLASH_OE_B	54	OE_B

Table 1-7: BPI Memory Connections (Cont'd)

FPGA U1 Pin	Schematic Netname	BPI Memory U10	
		Pin Number	Pin
L17	FLASH_CE_B	14	CE0
B3	FMC_PWR_GOOD_FLASH_RST_B	16	RP_B

Note: Memory U10 pin 56 address A24 is not connected on the 16 MB device. It is made available for larger density devices.

```

NET "FLASH_A0"                LOC = "K18";
NET "FLASH_A1"                LOC = "K17";
NET "FLASH_A2"                LOC = "J18";
NET "FLASH_A3"                LOC = "J16";
NET "FLASH_A4"                LOC = "G18";
NET "FLASH_A5"                LOC = "G16";
NET "FLASH_A6"                LOC = "H16";
NET "FLASH_A7"                LOC = "H15";
NET "FLASH_A8"                LOC = "H14";
NET "FLASH_A9"                LOC = "H13";
NET "FLASH_A10"               LOC = "F18";
NET "FLASH_A11"               LOC = "F17";
NET "FLASH_A12"               LOC = "K13";
NET "FLASH_A13"               LOC = "K12";
NET "FLASH_A14"               LOC = "E18";
NET "FLASH_A15"               LOC = "E16";
NET "FLASH_A16"               LOC = "G13";
NET "FLASH_A17"               LOC = "H12";
NET "FLASH_A18"               LOC = "D18";
NET "FLASH_A19"               LOC = "D17";
NET "FLASH_A20"               LOC = "G14";
NET "FLASH_A21"               LOC = "F14";
NET "FLASH_A22"               LOC = "C18";
NET "FLASH_A23"               LOC = "C17";
NET "FLASH_A24"               LOC = "F16";

NET "FPGA_D0_DIN_MISO_MISO1"  LOC = "R13";
NET "FPGA_D1_MISO2"           LOC = "T14";
NET "FPGA_D2_MISO3"           LOC = "V14";
NET "FLASH_D3"                LOC = "U5";
NET "FLASH_D4"                LOC = "V5";
NET "FLASH_D5"                LOC = "R3";
NET "FLASH_D6"                LOC = "T3";
NET "FLASH_D7"                LOC = "R5";

NET "FLASH_WE_B"              LOC = "M16";
NET "FLASH_OE_B"              LOC = "L18";
NET "FLASH_CE_B"              LOC = "L17";
NET "FMC_PWR_GOOD_FLASH_RST_B" LOC = "B3";

```

Figure 1-10: UCF Location Constraints for BPI Flash Connections

References

See the Numonyx Flash Memory specifications for more information at http://www.numonyx.com/Documents/Datasheets/308551_J3D_Discrete_DS.pdf.

In addition, see the Xilinx Spartan-6 Configuration User Guide for more information at http://www.xilinx.com/support/documentation/user_guides/ug380.pdf.

5. 10/100/1000 Tri-Speed Ethernet PHY

The SP601 uses the onboard Marvell Alaska PHY device (88E1111) for Ethernet communications at 10, 100, or 1000 Mb/s. The board supports a GMII/MII interface from the FPGA to the PHY. The PHY connection to a user-provided Ethernet cable is through a Halo HFJ11-1G01E RJ-45 connector with built-in magnetics.

On power-up, or on reset, the PHY is configured to operate in GMII mode with PHY address 0b00111 using the settings shown in [Table 1-8](#). These settings can be overwritten via software commands passed over the MDIO interface.

Table 1-8: PHY Configuration Pins

Pin	Connection on Board	Bit[2] Definition and Value	Bit[1] Definition and Value	Bit[0] Definition and Value
CFG0	V _{CC} 2.5V	PHYADR[2] = 1	PHYADR[1] = 1	PHYADR[0] = 1
CFG1	Ground	ENA_PAUSE = 0	PHYADR[4] = 0	PHYADR[3] = 0
CFG2	V _{CC} 2.5V	ANEG[3] = 1	ANEG[2] = 1	ANEG[1] = 1
CFG3	V _{CC} 2.5V	ANEG[0] = 1	ENA_XC = 1	DIS_125 = 1
CFG4	V _{CC} 2.5V	HWCFG_MD[2] = 1	HWCFG_MD[1] = 1	HWCFG_MD[0] = 1
CFG5	V _{CC} 2.5V	DIS_FC = 1	DIS_SLEEP = 1	HWCFG_MD[3] = 1
CFG6	PHY_LED_RX	SEL_BDT = 0	INT_POL = 1	75/50 OHM = 0

Table 1-9: PHY Connections

FPGA U1 Pin	Schematic Netname	U3 M88E111
P16	PHY_MDIO	33
N14	PHY_MDC	35
J13	PHY_INT	32
L13	PHY_RESET	36
M13	PHY_CRIS	115
L14	PHY_COL	114
L16	PHY_RXCLK	7
P17	PHY_RXER	8
N18	PHY_RXCTL_RXDV	4
M14	PHY_RXD0	3
U18	PHY_RXD1	128
U17	PHY_RXD2	126
T18	PHY_RXD3	125
T17	PHY_RXD4	124
N16	PHY_RXD5	123
N15	PHY_RXD6	121

Table 1-9: PHY Connections (Cont'd)

FPGA U1 Pin	Schematic Netname	U3 M88E111
P18	PHY_RXD7	120
A9	PHY_TXC_GTXCLK	14
B9	PHY_TXCLK	10
A8	PHY_TXER	13
B8	PHY_TXCTL_TXEN	16
F8	PHY_TXD0	18
G8	PHY_TXD1	19
A6	PHY_TXD2	20
B6	PHY_TXD3	24
E6	PHY_TXD4	25
F7	PHY_TXD5	26
A5	PHY_TXD6	28
C5	PHY_TXD7	29

```

NET "PHY_COL"                LOC = "L14";
NET "PHY_CRS"                LOC = "M13";
NET "PHY_INT"                LOC = "J13";
NET "PHY_MDC"                LOC = "N14";
NET "PHY_MDIO"               LOC = "P16";
NET "PHY_RESET"              LOC = "L13";
NET "PHY_RXCLK"              LOC = "L16";
NET "PHY_RXCTL_RXDV"         LOC = "N18";
NET "PHY_RXD0"                LOC = "M14";
NET "PHY_RXD1"                LOC = "U18";
NET "PHY_RXD2"                LOC = "U17";
NET "PHY_RXD3"                LOC = "T18";
NET "PHY_RXD4"                LOC = "T17";
NET "PHY_RXD5"                LOC = "N16";
NET "PHY_RXD6"                LOC = "N15";
NET "PHY_RXD7"                LOC = "P18";
NET "PHY_RXER"                LOC = "P17";
NET "PHY_TXCLK"               LOC = "B9";
NET "PHY_TXCTL_TXEN"         LOC = "B8";
NET "PHY_TXC_GTXCLK"         LOC = "A9";
NET "PHY_TXD0"                LOC = "F8";
NET "PHY_TXD1"                LOC = "G8";
NET "PHY_TXD2"                LOC = "A6";
NET "PHY_TXD3"                LOC = "B6";
NET "PHY_TXD4"                LOC = "E6";
NET "PHY_TXD5"                LOC = "F7";
NET "PHY_TXD6"                LOC = "A5";
NET "PHY_TXD7"                LOC = "C5";
NET "PHY_TXER"                LOC = "A8";

```

Figure 1-11: UCF Location Constraints for PHY Connections

References

See the Marvell Alaska Gigabit Ethernet Transceiver product page for more information at http://www.marvell.com/products/transceivers/alaska_gigabit/index.jsp.

Also, see the Xilinx Tri-Mode Ethernet MAC User Guide at http://www.xilinx.com/support/documentation/ip_documentation/tri_mode_eth_mac_ug138.pdf.

6. USB-to-UART Bridge

The SP601 contains a Silicon Labs CP2103GM USB-to-UART bridge device (U4) which allows connection to a host computer with a USB cable. The USB cable is supplied in this evaluation kit (Type A end to host computer, Type Mini-B end to SP601 connector J9). [Table 1-10](#) details the SP601 J9 pinout.

[Table 1-10](#) details the SP601 J9 pinout.

Xilinx UART IP is expected to be implemented in the FPGA fabric. The FPGA supports the USB-to-UART bridge using four signal pins, transmit (TX), receive (RX), Request to Send (RTS), and Clear to Send (CTS).

Silicon Labs provides royalty-free Virtual COM Port (VCP) drivers which permit the CP2103GM USB-to-UART bridge to appear as a COM port to host computer communications application software (for example, HyperTerm or TeraTerm). The VCP device driver must be installed on the host PC prior to establishing communications with the SP601. Refer to the *SP601 Getting Started Guide* for driver installation instructions.

Table 1-10: USB Type B Pin Assignments and Signal Definitions

USB Connector Pin	Signal Name	Description
1	VBUS	+5V from host system (not used)
2	USB_DATA_N	Bidirectional differential serial data (N-side)
3	USB_DATA_P	Bidirectional differential serial data (P-side)
4	GROUND	Signal ground

Table 1-11: CP2103GM Connections

FPGA U1 Pin	Schematic Netname	U4 CP2103GM
U10	USB_1_CTS	22
T5	USB_1_RTS	23
L12	USB_1_RX	24
K14	USB_1_TX	25

```

NET "USB_1_CTS"          LOC = "U10";
NET "USB_1_RTS"         LOC = "T5";
NET "USB_1_RX"          LOC = "L12";
NET "USB_1_TX"          LOC = "K14";
    
```

Figure 1-12: UCF Location Constraints for CP2103GM Connections

References

Technical information on the Silicon Labs CP2103GM and the VCP drivers can be found on their website at <https://www.silabs.com/Pages/default.aspx>.

In addition, see some of the Xilinx UART IP specifications at:

- http://www.xilinx.com/support/documentation/ip_documentation/opb_uartlite.pdf
- http://www.xilinx.com/support/documentation/ip_documentation/xps_uartlite.pdf
- http://www.xilinx.com/support/documentation/ip_documentation/xps_uart16550.pdf

7. IIC Bus

The SP601 IIC bus hosts four items:

- FPGA U1 IIC interface
- 2-pin IIC external access header
- 8-Kb NV Memory
- VITA 57.1 FMC Connector J1

The SP601 IIC bus topology is shown in [Figure 1-13](#).

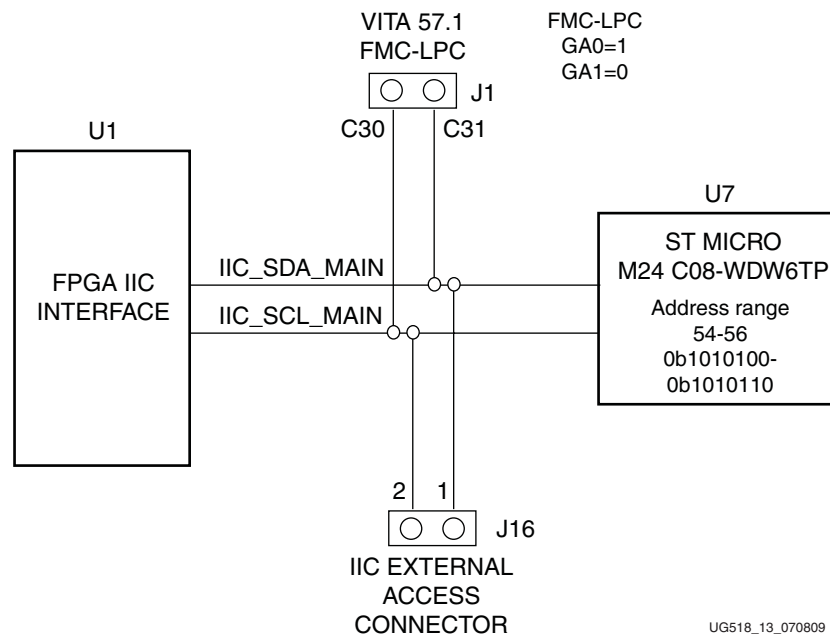

Figure 1-13: IIC Bus Topology

The IIC Bus on the SP601 provides access to a 2-pin header, the onboard 8-Kb EEPROM, and the VITA 57.1 FMC interface. The user must ensure there are no IIC address conflicts with the onboard EEPROM address when attaching additional IIC devices via FMC or the IIC 2-pin header. Note that FMC Mezzanine cards are designed with 2-Kb IIC EEPROMs and will not conflict with the Carrier Card (SP601) 8-Kb EEPROM address range. This is because 2-Kb EEPROMs reside below the 8-Kb EEPROM space. See the VITA 57.1 specification along with any IIC 2-Kbit EEPROM data sheet for more details.

8-Kb NV Memory

The SP601 hosts a 8-Kb ST Microelectronics M24C08-WDW6TP IIC parameter storage memory device (U7). The IIC address of U7 is 0b1010100, and U7 is not write protected (WP pin 7 is tied to GND).

Table 1-12: IIC Memory Connections

FPGA U1 Pin Number	Schematic Netname	SPI Memory U7	
		Pin Number	Pin
Not Applicable	Tied to GND	1	A0
Not Applicable	Tied to GND	2	A1
Not Applicable	Pulled up (0 ohm) to VCC3V3	3	A2
N10	IIC_SDA_MAIN	5	SDA
P11	IIC_SCL_MAIN	6	SCL
Not Applicable	Tied to GND	7	WP

```
NET "IIC_SCL_MAIN"          LOC = "P11";
NET "IIC_SDA_MAIN"        LOC = "N10";
```

Figure 1-14: UCF Location Constraints for IIC Connections

References

See the ST Micro M24C08-WDW6TP data sheet for more information at <http://www.st.com/stonline/products/literature/ds/5067/m24c08-w.pdf>.

In addition, see the Xilinx XPS IIC Bus Interface specification at http://www.xilinx.com/support/documentation/ip_documentation/xps_iic.pdf.

Also, see “9. VITA 57.1 FMC-LPC Connector,” page 28.

8. Clock Generation

There are three clock sources available on the SP601.

Oscillator (Differential)

The SP601 has one 2.5V LVDS differential 200 MHz oscillator (U5) soldered onto the board and wired to an FPGA global clock input.

- Crystal oscillator: Epson EG2121CA
- PPM frequency jitter: 50 ppm

```
NET "SYSCLK_N"             LOC = "K16";
NET "SYSCLK_P"            LOC = "K15";
```

Figure 1-15: UCF Location Constraints for Oscillator Connections

References

For more details, see the Epson data sheet at <http://www.epsontoyocom.co.jp/english/product/OSC/set04/eg2121ca/index.html>.

Oscillator Socket (Single-Ended, 2.5V or 3.3V)

One populated single-ended clock socket (X2) is provided for user applications. The option of 3.3V or 2.5V power may be selected via a 0 ohm resistor selection. The SP601 board is shipped with a 27MHz 2.5V oscillator installed.

```
NET "USER_CLOCK"                                LOC = "V10";
```

Figure 1-16: UCF Location Constraints for Oscillator Socket Connections

SMA Connectors (Differential)

A high-precision clock signal can be provided to the FPGA using differential clock signals through the onboard 50-ohm SMA connectors J7(P)/J8(N).

```
NET "SMACLK_N"                                LOC = "H18";
NET "SMACLK_P"                                LOC = "H17";
```

Figure 1-17: UCF Location Constraints for SMA Connectors Connections

9. VITA 57.1 FMC-LPC Connector

The VITA 57.1 FMC expansion connector (J1) on the SP601 implements the VITA 57.1.1 LPC format of the VITA 57.1 FMC standard specification. The VITA 57.1 FMC-LPC connector provides 68 single-ended (34 differential) user-defined signals (Table 1-13). The VITA 57.1 FMC standard calls for two connector densities: a High Pin Count (HPC) and a Low Pin Count (LPC) implementation. A common 10 x 40 position (400 pin locations) connector form factor is used for both versions. The HPC version has 400 pins present, the LPC version, 160 pins. The Samtec connector system is rated for signaling speeds up to 9 GHz (18 Gb/s) based on a -3dB insertion loss point within a two-level signaling environment. Refer to the [Samtec website](#) for data sheets and characterization information for the RoHS-compliant VITA 57.1 FMC-LPC connector (ASP-134603-01) and its mate.

Note that the SP601 board FMC-LPC connector J1 VADJ voltage is FIXED at 2.5V (non-adjustable). This rail cannot be turned off. The SP601 VITA 57.1 FMC interface is compatible with 2.5V Mezzanine Cards capable of supporting 2.5V VADJ.

The SP601 supports all FMC LA Bus connections available on the FMC LPC connector, (LA[00:33]) along with all available FMC M2C clock pairs (CLK0_M2C_P/N and CLK1_M2C_P/N). The SP601 does not support the FMC DP Bus connections since the SP601 does not support any Gigabit Transceivers on the FMC DP Bus. Therefore, DP0_C2M_P/N, DP0_M2C_P/N and GBTCLK0_M2C_P/N are not supported by the SP601 FMC interface.

For more details about FMC, see the VITA57.1 specification available at <http://www.vita.com/fmc.html>.

Table 1-13: LPC Pinout

	K	J	H	G	F	E	D	C	B	A
1	NC	NC	VREF_A_M2C	GND	NC	NC	PG_C2M	GND	NC	NC
2	NC	NC	PRSNT_M2C_L	CLK1_M2C_P	NC	NC	GND	DP0_C2M_P	NC	NC
3	NC	NC	GND	CLK1_M2C_N	NC	NC	GND	DP0_C2M_N	NC	NC
4	NC	NC	CLK0_M2C_P	GND	NC	NC	GBTCLK0_M2C_P	GND	NC	NC
5	NC	NC	CLK0_M2C_N	GND	NC	NC	GBTCLK0_M2C_N	GND	NC	NC
6	NC	NC	GND	LA00_P_CC	NC	NC	GND	DP0_M2C_P	NC	NC
7	NC	NC	LA02_P	LA00_N_CC	NC	NC	GND	DP0_M2C_N	NC	NC
8	NC	NC	LA02_N	GND	NC	NC	LA01_P_CC	GND	NC	NC
9	NC	NC	GND	LA03_P	NC	NC	LA01_N_CC	GND	NC	NC
10	NC	NC	LA04_P	LA03_N	NC	NC	GND	LA06_P	NC	NC
11	NC	NC	LA04_N	GND	NC	NC	LA05_P	LA06_N	NC	NC
12	NC	NC	GND	LA08_P	NC	NC	LA05_N	GND	NC	NC
13	NC	NC	LA07_P	LA08_N	NC	NC	GND	GND	NC	NC
14	NC	NC	LA07_N	GND	NC	NC	LA09_P	LA10_P	NC	NC
15	NC	NC	GND	LA12_P	NC	NC	LA09_N	LA10_N	NC	NC
16	NC	NC	LA11_P	LA12_N	NC	NC	GND	GND	NC	NC
17	NC	NC	LA11_N	GND	NC	NC	LA13_P	GND	NC	NC
18	NC	NC	GND	LA16_P	NC	NC	LA13_N	LA14_P	NC	NC
19	NC	NC	LA15_P	LA16_N	NC	NC	GND	LA14_N	NC	NC
20	NC	NC	LA15_N	GND	NC	NC	LA17_P_CC	GND	NC	NC
21	NC	NC	GND	LA20_P	NC	NC	LA17_N_CC	GND	NC	NC
22	NC	NC	LA19_P	LA20_N	NC	NC	GND	LA18_P_CC	NC	NC
23	NC	NC	LA19_N	GND	NC	NC	LA23_P	LA18_N_CC	NC	NC
24	NC	NC	GND	LA22_P	NC	NC	LA23_N	GND	NC	NC
25	NC	NC	LA21_P	LA22_N	NC	NC	GND	GND	NC	NC
26	NC	NC	LA21_N	GND	NC	NC	LA26_P	LA27_P	NC	NC
27	NC	NC	GND	LA25_P	NC	NC	LA26_N	LA27_N	NC	NC
28	NC	NC	LA24_P	LA25_N	NC	NC	GND	GND	NC	NC
29	NC	NC	LA24_N	GND	NC	NC	TCK	GND	NC	NC
30	NC	NC	GND	LA29_P	NC	NC	TDI	SCL	NC	NC
31	NC	NC	LA28_P	LA29_N	NC	NC	TDO	SDA	NC	NC
32	NC	NC	LA28_N	GND	NC	NC	3P3VAUX	GND	NC	NC
33	NC	NC	GND	LA31_P	NC	NC	TMS	GND	NC	NC

Table 1-13: LPC Pinout (Cont'd)

	K	J	H	G	F	E	D	C	B	A
34	NC	NC	LA30_P	LA31_N	NC	NC	TRST_L	GA0	NC	NC
35	NC	NC	LA30_N	GND	NC	NC	GA1	12P0V	NC	NC
36	NC	NC	GND	LA33_P	NC	NC	3P3V	GND	NC	NC
37	NC	NC	LA32_P	LA33_N	NC	NC	GND	12P0V	NC	NC
38	NC	NC	LA32_N	GND	NC	NC	3P3V	GND	NC	NC
39	NC	NC	GND	VADJ	NC	NC	GND	3P3V	NC	NC
40	NC	NC	VADJ	GND	NC	NC	3P3V	GND	NC	NC

```

NET "FMC_CLK0_M2C_N"          LOC = "A10";
NET "FMC_CLK0_M2C_P"          LOC = "C10";
NET "FMC_CLK1_M2C_N"          LOC = "V9";
NET "FMC_CLK1_M2C_P"          LOC = "T9";
NET "FMC_LA00_CC_N"           LOC = "C9";
NET "FMC_LA00_CC_P"           LOC = "D9";
NET "FMC_LA01_CC_N"           LOC = "C11";
NET "FMC_LA01_CC_P"           LOC = "D11";
NET "FMC_LA02_N"              LOC = "A15";
NET "FMC_LA02_P"              LOC = "C15";
NET "FMC_LA03_N"              LOC = "A13";
NET "FMC_LA03_P"              LOC = "C13";
NET "FMC_LA04_N"              LOC = "A16";
NET "FMC_LA04_P"              LOC = "B16";
NET "FMC_LA05_N"              LOC = "A14";
NET "FMC_LA05_P"              LOC = "B14";
NET "FMC_LA06_N"              LOC = "C12";
NET "FMC_LA06_P"              LOC = "D12";
NET "FMC_LA07_N"              LOC = "E8";
NET "FMC_LA07_P"              LOC = "E7";
NET "FMC_LA08_N"              LOC = "E11";
NET "FMC_LA08_P"              LOC = "F11";
NET "FMC_LA09_N"              LOC = "F10";
NET "FMC_LA09_P"              LOC = "G11";
NET "FMC_LA10_N"              LOC = "C8";
NET "FMC_LA10_P"              LOC = "D8";
NET "FMC_LA11_N"              LOC = "A12";
NET "FMC_LA11_P"              LOC = "B12";
NET "FMC_LA12_N"              LOC = "C6";
NET "FMC_LA12_P"              LOC = "D6";
NET "FMC_LA13_N"              LOC = "A11";
NET "FMC_LA13_P"              LOC = "B11";
NET "FMC_LA14_N"              LOC = "A2";
NET "FMC_LA14_P"              LOC = "B2";
NET "FMC_LA15_N"              LOC = "F9";
NET "FMC_LA15_P"              LOC = "G9";
NET "FMC_LA16_N"              LOC = "A7";
NET "FMC_LA16_P"              LOC = "C7";
NET "FMC_LA17_CC_N"           LOC = "T8";
NET "FMC_LA17_CC_P"           LOC = "R8";
NET "FMC_LA18_CC_N"           LOC = "T10";
NET "FMC_LA18_CC_P"           LOC = "R10";
NET "FMC_LA19_N"              LOC = "P7";
NET "FMC_LA19_P"              LOC = "N6";
NET "FMC_LA20_N"              LOC = "P8";
NET "FMC_LA20_P"              LOC = "N7";
NET "FMC_LA21_N"              LOC = "V4";
NET "FMC_LA21_P"              LOC = "T4";
NET "FMC_LA22_N"              LOC = "T7";
NET "FMC_LA22_P"              LOC = "R7";
NET "FMC_LA23_N"              LOC = "P6";
NET "FMC_LA23_P"              LOC = "N5";
NET "FMC_LA24_N"              LOC = "V8";
NET "FMC_LA24_P"              LOC = "U8";
NET "FMC_LA25_N"              LOC = "N11";
NET "FMC_LA25_P"              LOC = "M11";
NET "FMC_LA26_N"              LOC = "V7";
NET "FMC_LA26_P"              LOC = "U7";
NET "FMC_LA27_N"              LOC = "T11";
NET "FMC_LA27_P"              LOC = "R11";
NET "FMC_LA28_N"              LOC = "V11";
NET "FMC_LA28_P"              LOC = "U11";
NET "FMC_LA29_N"              LOC = "N8";
NET "FMC_LA29_P"              LOC = "M8";
NET "FMC_LA30_N"              LOC = "V12";
NET "FMC_LA30_P"              LOC = "T12";
NET "FMC_LA31_N"              LOC = "V6";
NET "FMC_LA31_P"              LOC = "T6";
NET "FMC_LA32_N"              LOC = "V15";
NET "FMC_LA32_P"              LOC = "U15";
NET "FMC_LA33_N"              LOC = "N9";
NET "FMC_LA33_P"              LOC = "M10";
NET "FMC_PRSNNT_M2C_L"        LOC = "U13";
NET "FMC_PWR_GOOD_FLASH_RST_B" LOC = "B3";

```

Figure 1-18: UCF Location Constraints for VITA 57.1 FMC-LPC Connections

10. Status LEDs

Table 1-14 defines the status LEDs.

Table 1-14: **Status LEDs**

Reference Designator	Signal Name	Color	Label	Description
DS1	FMC_PWR_GOOD_FLASH_RST_B	Green	PWR GOOD	Indicates power available for VITA 57.1 FMC expansion connector.
DS2	PHY_LED_LINK10	Green	10	
DS3	PHY_LED_LINK100	Green	100	
DS4	PHY_LED_LINK100_0	Green	1000	
DS5	PHY_LED_DUPLEX	Green	DUP	
DS6	PHY_LED_RX	Green	RX	
DS7	PHY_LED_TX	Green	TX	
DS8	FPGA_AWAKE	Green	AWAKE	
DS9	FPGA_DONE	Green	DONE	Illuminates to indicate the status of the DONE pin when the FPGA is successfully configured.
DS10	FPGA_INIT	Red	INIT	Illuminates after power-up to indicate that the FPGA has successfully powered up and completed its internal power-on process.
DS15	VCC5	Green		Illuminates when 5V supply is applied.
DS16	LED_GRN, LED_RED	Green/ Red	STATUS	USB to JTAG logic.
DS17	LTC_PWR_GOOD	Green		Illuminates to indicate that the board power is good.

11. FPGA Awake LED and Suspend Jumper

The suspend mode jumper permits the FPGA to enter an inactive, "suspend" mode. The FPGA Awake LED DS8 will go out when the FPGA enters this mode.

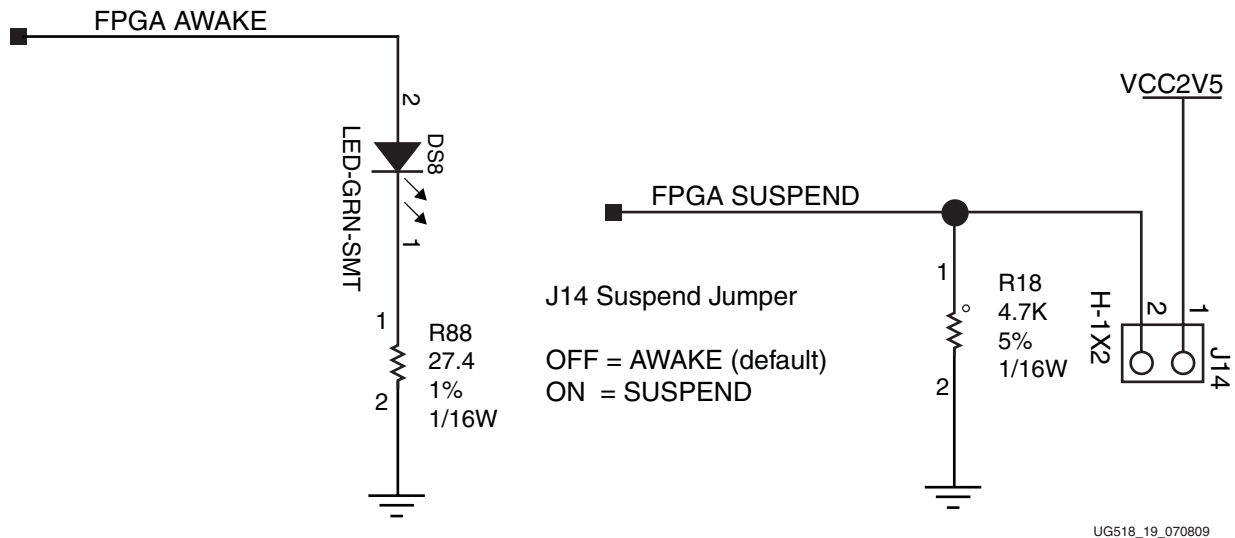

UG518_19_070809

Figure 1-19: FPGA Awake LED and Suspend Jumper

Table 1-15: FPGA Awake/Suspend Mode Jumper Connections

FPGA U1 Pin	Schematic Netname	Suspend Mode I/O
P15	FPGA_AWAKE	Awake LED DS8.2
R16	FPGA_SUSPEND	Suspend J14.2

```
NET "FPGA_AWAKE"          LOC = "P15";
NET "FPGA_SUSPEND"       LOC = "R16";
```

Figure 1-20: UCF Location Constraints for FPGA Awake/Suspend Mode Jumper

See the *Spartan-6 FPGA Configuration Guide* for more information at http://www.xilinx.com/support/documentation/user_guides/ug380.pdf.

12. FPGA INIT and DONE LEDs

The typical Xilinx FPGA power up and configuration status LEDs are present on the SP601. The INIT LED DS10 comes on after the FPGA powers up and completes its internal power-on process. The DONE LED DS9 comes on after the FPGA programming bitstream has been downloaded and the FPGA successfully configured.

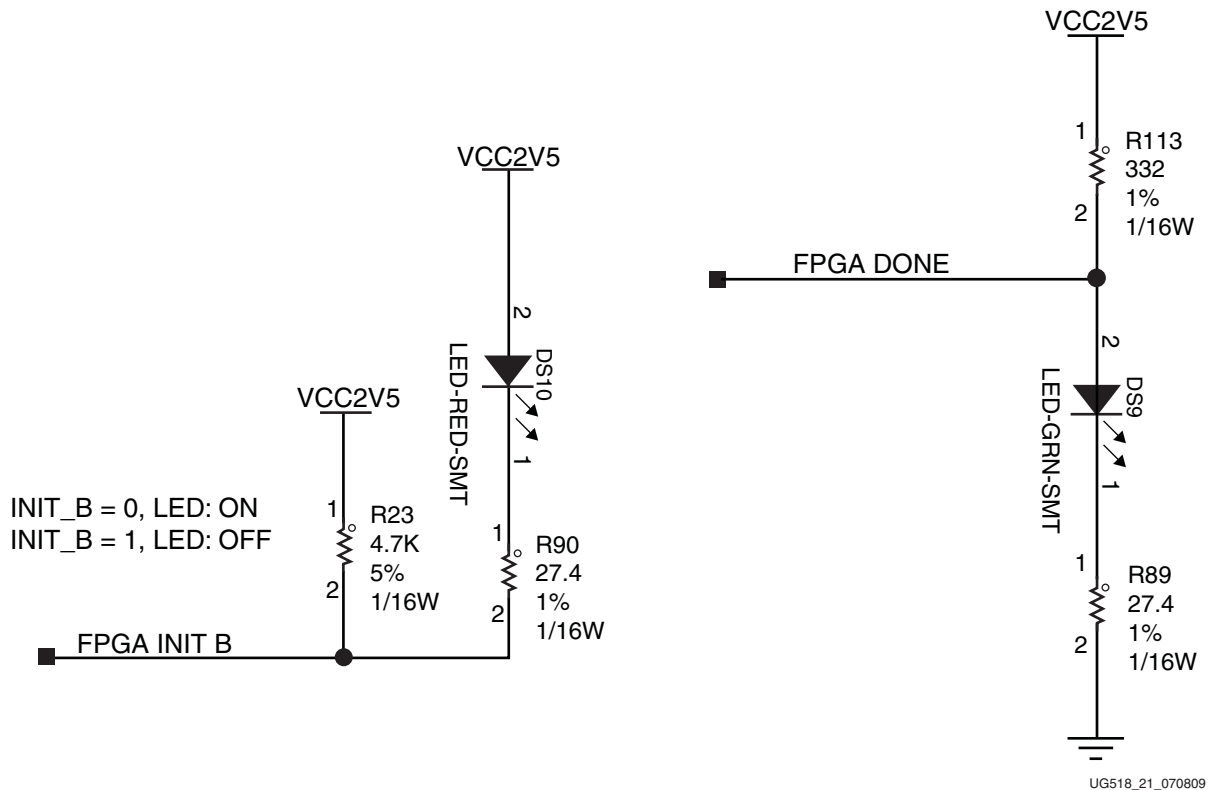

Figure 1-21: FPGA INIT and DONE LEDs

Table 1-16: FPGA INIT and DONE LED Connections

FPGA U1 Pin	Schematic Netname	Controlled LED
U3	FPGA_INIT_B	DS10 INIT
V17	FPGA_DONE	DS9 DONE

```
NET "FPGA_INIT_B"                LOC = "U3";
NET "FPGA_DONE"                  LOC = "V17";
```

Figure 1-22: UCF Location Constraints for FPGA INIT and DONE

13. User I/O

The SP601 provides the following user and general purpose I/O capabilities:

- User LEDs
- User DIP switch
- Pushbutton switches
- CPU Reset pushbutton switch
- GPIO male pin header

Note: All GPIO location constraints are collected in one partial UCF in [Figure 1-27](#).

User LEDs

The SP601 provides four active high, green LEDs, as described in [Figure 1-23](#) and [Table 1-17](#).

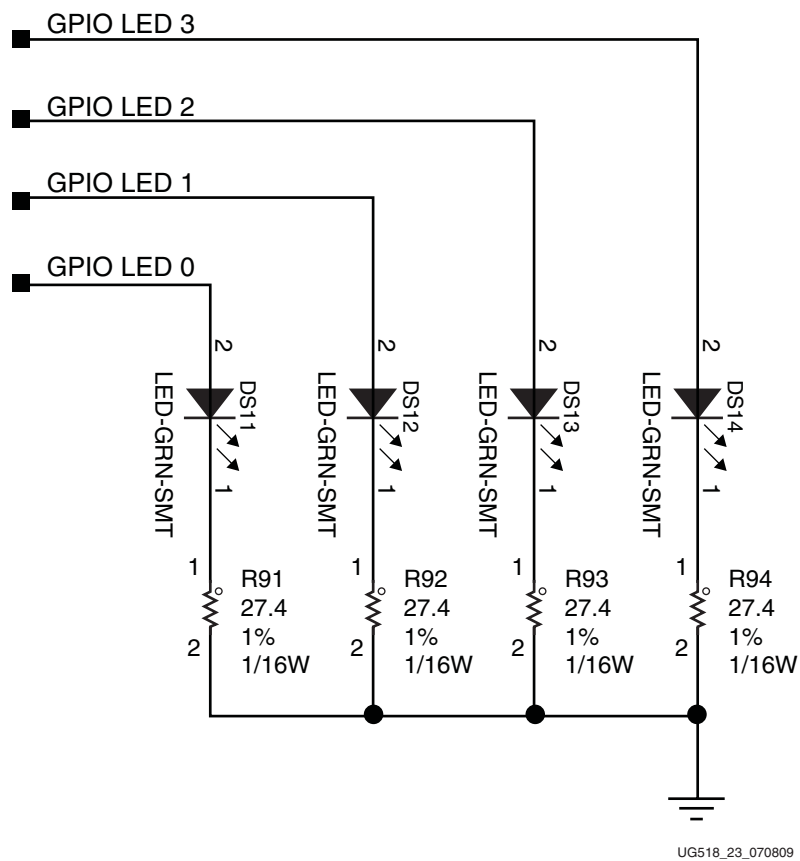

Figure 1-23: User LEDs

Table 1-17: User LEDs

Reference Designator	Signal Name	Color	Label	FPGA Pin
DS11	GPIO_LED_0	Green		E13
DS12	GPIO_LED_1	Green		C14

Table 1-17: User LEDs (Cont'd)

Reference Designator	Signal Name	Color	Label	FPGA Pin
DS13	GPIO_LED_2	Green		C4
DS14	GPIO_LED_3	Green		A4

User DIP switch

The SP601 includes an active high four pole DIP switch, as described in [Figure 1-24](#) and [Table 1-18](#).

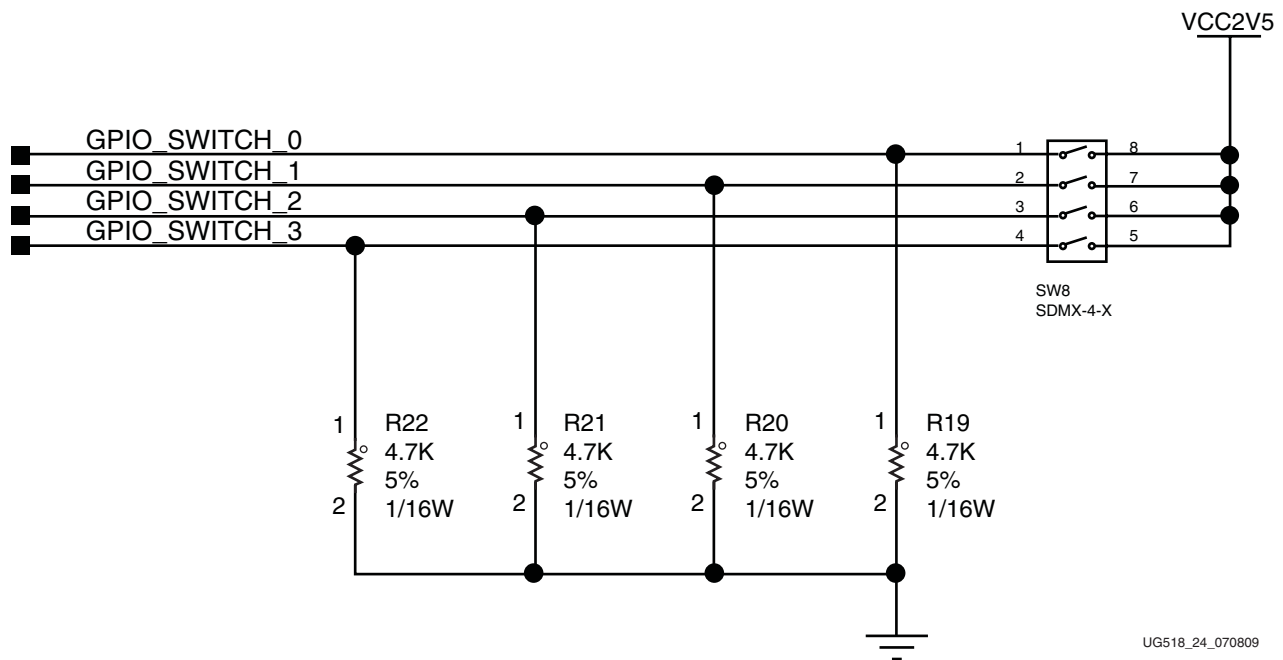

Figure 1-24: User DIP Switch

Table 1-18: User DIP Switch Connections

FPGA U1 Pin	Schematic Netname	SW8 Pin Number
D14	GPIO_SWITCH_0	1
E12	GPIO_SWITCH_1	2
F12	GPIO_SWITCH_2	3
V13	GPIO_SWITCH_3	4

User Pushbutton Switches

The SP601 provides five active high pushbutton switches: SW6, SW4, SW5, SW7 and SW9. The five pushbuttons all have the same topology as the sample shown in Figure 1-25. Four pushbuttons are assigned as GPIO, and the fifth is assigned as a CPU_RESET. Figure 1-25 and Table 1-19 describe the pushbutton switches.

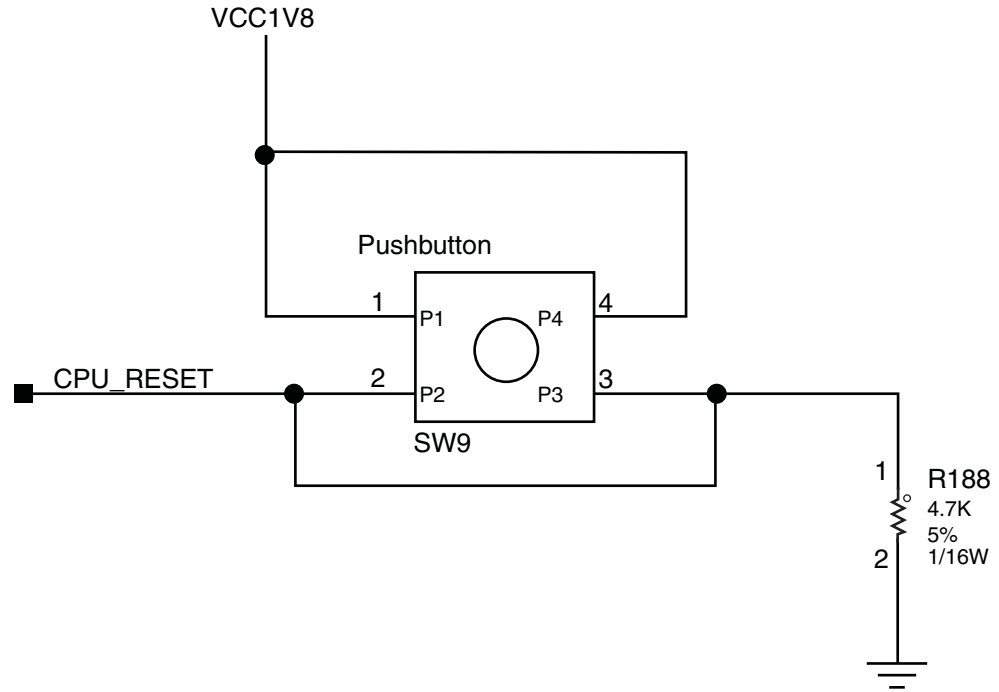

UG518_25_070809

Figure 1-25: User Pushbutton Switch (Typical)

Table 1-19: Pushbutton Switch Connections

FPGA U1 Pin	Schematic Netname	Switch Pin
P4	GPIO_BUTTON_0	SW6.2
F6	GPIO_BUTTON_1	SW4.2
E4	GPIO_BUTTON_2	SW5.2
F5	GPIO_BUTTON_3	SW7.2
N4	CPU_RESET	SW9.2

GPIO Male Pin Header

The SP601 provides a 2X6 GPIO male pin header supporting 3.3V power, GND and eight I/Os. Figure 1-26 and Table 1-20 describe the J13 GPIO Male Pin Header.

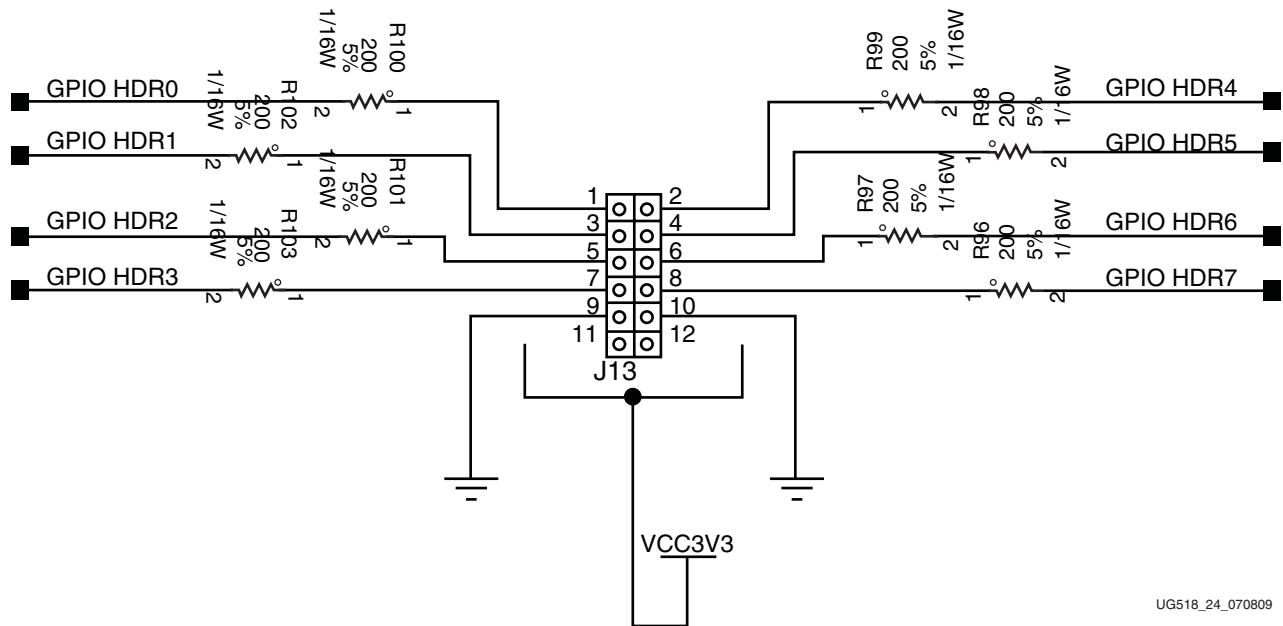

UG518_24_070809

Figure 1-26: GPIO Male Pin Header Topology

Table 1-20: GPIO Header Pins

FPGA U1 Pin	Signal Name	J13 Pin
N17	GPIO_HDR0	1
M18	GPIO_HDR1	3
A3	GPIO_HDR2	5
L15	GPIO_HDR3	7
F15	GPIO_HDR4	2
B4	GPIO_HDR5	4
F13	GPIO_HDR6	6
P12	GPIO_HDR7	8

```
NET "GPIO_LED_0"          LOC = "E13";
NET "GPIO_LED_1"          LOC = "C14";
NET "GPIO_LED_2"          LOC = "C4";
NET "GPIO_LED_3"          LOC = "A4";

NET "GPIO_SWITCH_0"       LOC = "D14";
NET "GPIO_SWITCH_1"       LOC = "E12";
NET "GPIO_SWITCH_2"       LOC = "F12";
NET "GPIO_SWITCH_3"       LOC = "V13";

NET "GPIO_BUTTON0"        LOC = "P4";
NET "GPIO_BUTTON1"        LOC = "F6";
NET "GPIO_BUTTON2"        LOC = "E4";
NET "GPIO_BUTTON3"        LOC = "F5";
NET "CPU_RESET"           LOC = "N4";

NET "GPIO_HDR0"           LOC = "N17";
NET "GPIO_HDR1"           LOC = "M18";
NET "GPIO_HDR2"           LOC = "A3";
NET "GPIO_HDR3"           LOC = "L15";
NET "GPIO_HDR4"           LOC = "F15";
NET "GPIO_HDR5"           LOC = "B4";
NET "GPIO_HDR6"           LOC = "F13";
NET "GPIO_HDR7"           LOC = "P12";
```

Figure 1-27: UCF Location Constraints for User and General-Purpose I/O

14. FPGA_PROG_B Pushbutton Switch

The SP601 provides one dedicated, active low FPGA_PROG_B pushbutton switch, as shown in [Figure 1-28](#).

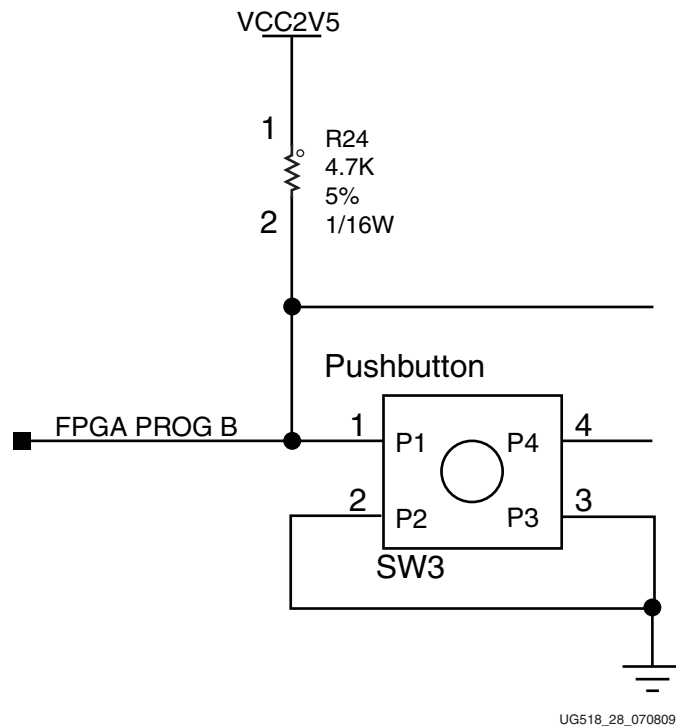

Figure 1-28: FPGA_PROG_B Pushbutton Switch Topology

Table 1-21: FPGA_PROG_B Pushbutton Switch Connections

FPGA U1 Pin	Schematic Netname	SW3 Pin
V2	FPGA_PROG_B	1

```
NET "FPGA_PROG_B" LOC = "V2";
```

Figure 1-29: UCF Location Constraints for BPI Flash Connections

Power Management

AC Adapter and 5V Input Power Jack/Switch

The SP601 is powered from a 5V source that is connected through a 2.1mm x 5.5mm type plug (center positive). SP601 power can be turned on or off through a board mounted slide switch. When the switch is in the on position, a green LED (DS15) is illuminated.

Onboard Power Supplies

The diagram in [Figure 1-30](#) shows the power supply architecture and maximum current handling on each supply. The typical operating currents are significantly below the maximum capable. The board is normally shipped with a 15W power supply, which should be sufficient for most applications.

The SP601 uses power solutions from LTC. An estimate of the current draw on the various power supply rails is shown in Table 1-22.

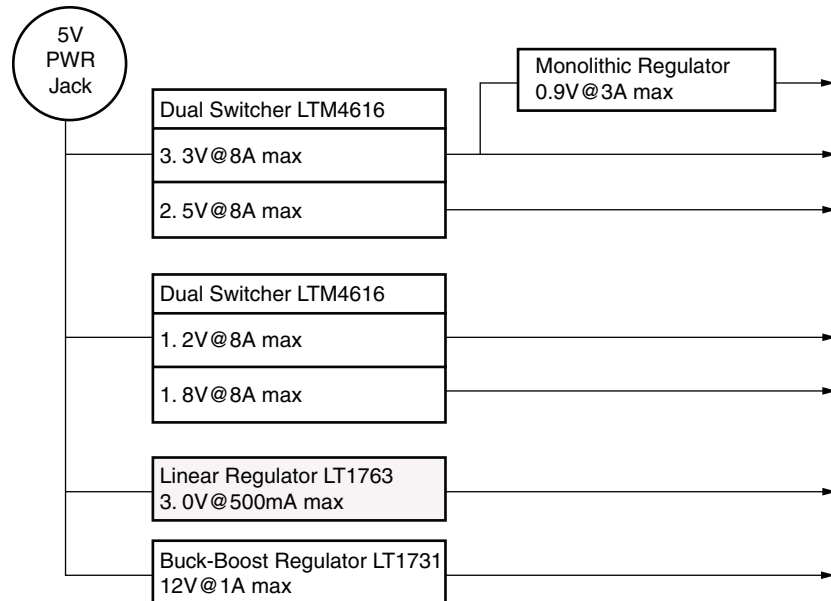

UG518_30_070809

Figure 1-30: Power Supply

Table 1-22: Estimated Current Draw

Rail (V)	Estimated Current (A)								Estimated Totals	LTC μ Module	Comments
	FMC	LX16 Int/Aux	LX16 V _{CCO}	DDR2	BPI/SPI Flash	USB CP2103	Clock Socket	Marvell EPHY			
12	1.0								1.0	LT1731	12V, 3A
3.3	3.0		2.0		0.3	0.1	0.1		5.5	(1/2) LTM4616	3.3V, 8A
2.5							0.1	1.0	1.1	(1/2) LTM4616	2.5V, 8A
1.8				1.0					1.3	(1/2) LTM4616	1.8V, 8A
1.2		3.0	2.0						5.0	(1/2) LTM4616	1.2V, 8A
V _{TT} 0.9				1.0					1.0	LTC3413	0.9V, 1.0A

Configuration Options

The FPGA on the SP601 Evaluation Board can be configured by the following methods:

- “3. SPI x4 Flash,” page 18
- “4. Linear Flash BPI,” page 20
- “JTAG Configuration,” page 42

For more information, refer to the *Spartan-6 FPGA Configuration User Guide*. [Ref 2]

Table 1-23: Mode Pin Settings (M2 = 0)

Mode Pins (M1, M0)	Configuration Mode
00	Master Byte Peripheral Interface (BPI)
01	Master SPI x1, x2, or x4
10	Not implemented on SP601
11	Not implemented on SP601

JTAG Configuration

JTAG configuration is provided through onboard USB-to-JTAG configuration logic where a computer host accesses the SP601 JTAG chain through a Type-A (computer host side) to Type-Mini-B (SP601 side) USB cable.

The JTAG chain of the board is illustrated in [Figure 1-31](#). JTAG configuration is allowable at any time under any mode pin setting. JTAG initiated configuration takes priority over the mode pin settings.

FMC bypass jumper J4 must be connected between pins 1-2 for JTAG access to the FPGA on the basic SP601 board, as shown in [Figure 1-31](#). When the VITA 57.1 FMC expansion connector is populated with an expansion module that has a JTAG chain, then jumper J4 must be set to connect pins 2-3 in order to include the FMC expansion module's JTAG chain in the main SP601 JTAG chain.

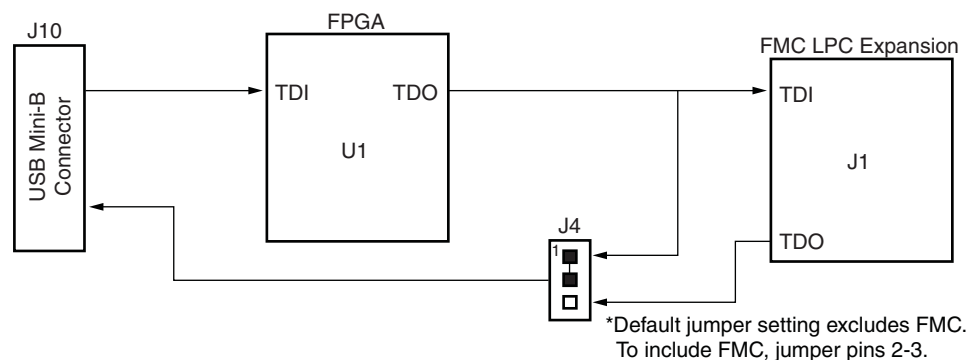

UG518_31_070809

Figure 1-31: JTAG Chain

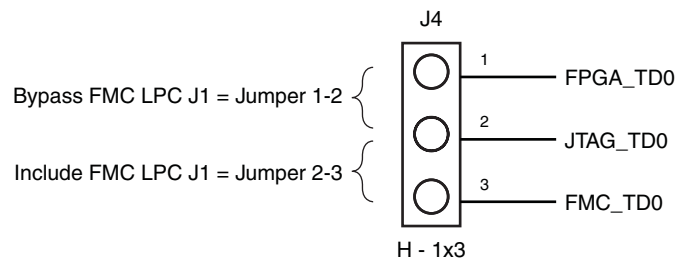

UG518_32_081909

Figure 1-32: VITA 57.1 FMC JTAG Bypass Jumper

The JTAG chain can be used to program the FPGA and access the FPGA for hardware and software debug.

The JTAG connector (USB Mini-B J10) allows a host computer to download bitstreams to the FPGA using the iMPACT software tool, and also allows debug tools such as the ChipScope™ Pro Analyzer tool or a software debugger to access the FPGA.

The iMPACT software tool can also program the SPI x4 flash or the BPI flash via the USB J10 connection. iMPACT can download a temporary design to the FPGA through the JTAG. This provides a connection within the FPGA from the FPGA's JTAG port to the FPGA's SPI or BPI interface. Through the connection made by the temporary design in the FPGA, iMPACT can indirectly program the SPI flash or BPI flash from the JTAG USB J10 connector.

References

This section provides references to documentation supporting Spartan-6 FPGAs, tools, and IP. For additional information, see www.xilinx.com/support/documentation/index.htm.

Documents supporting the SP601 Evaluation Board:

1. [UG138](#), *LogiCORE™ IP Tri-Mode Ethernet MAC v4.2 User Guide*
2. [UG380](#), *Spartan-6 FPGA Configuration User Guide*
3. [UG381](#), *Spartan-6 FPGA SelectIO Resources User Guide*
4. [UG388](#), *Spartan-6 FPGA Memory Controller User Guide*
5. [DS614](#), *Clock Generator (v3.01a) Data Sheet*
6. [DS643](#), *Multi-Port Memory Controller (MPMC) (v5.02a) Data Sheet*

Default Jumper and Switch Settings

Table B-1 shows the default jumper and switch settings for the SP601.

Table B-1: **Default Jumper and Switch Settings**

REFDES	Type/Function	Default
SW1	SLIDE, POWER ON-OFF	OFF
SW2	DIP, 2-POLE, MODE	
1	M0	ON (1)
2	M1	OFF (0)
SW8	DIP, 4-POLE, GPIO	
1		OFF
2		OFF
3		OFF
4		OFF
J4	HDR_1X3, JTAG BYPASS	JUMP 1-2 (EXCLUDE FMC)
J14	HDR_1X2, SUSPEND	OPEN (0 = AWAKE)
J15	HDR_1X2, SPI SELECT	ON (U17 SPI MEM SELECTED)

VITA 57.1 FMC Connections

Table C-1 shows the VITA 57.1 FMC LPC connections.

Table C-1: VITA 57.1 FMC LPC Connections

J1 FMC LPC Pin	Schematic Netname	U1 FPGA Pin	J1 FMC LPC Pin	Schematic Netname	U1 FPGA Pin
C10	FMC_LA06_P	D12	D1	FMC_PWR_GOOD_FLASH_RST_B	B3
C11	FMC_LA06_N	C12	D8	FMC_LA01_CC_P	D11
C14	FMC_LA10_P	D8	D9	FMC_LA01_CC_N	C11
C15	FMC_LA10_N	C8	D11	FMC_LA05_P	B14
C18	FMC_LA14_P	B2	D12	FMC_LA05_N	A14
C19	FMC_LA14_N	A2	D14	FMC_LA09_P	G11
C22	FMC_LA18_CC_P	R10	D15	FMC_LA09_N	F10
C23	FMC_LA18_CC_N	T10	D17	FMC_LA13_P	B11
C26	FMC_LA27_P	R11	D18	FMC_LA13_N	A11
C27	FMC_LA27_N	T11	D20	FMC_LA17_CC_P	R8
C30	IIC_SCL_MAIN	P11	D21	FMC_LA17_CC_N	T8
C31	IIC_SDA_MAIN	N10	D23	FMC_LA23_P	N5
			D24	FMC_LA23_N	P6
			D26	FMC_LA26_P	U7
			D27	FMC_LA26_N	V7
G2	FMC_CLK1_M2C_P	T9	H2	FMC_PRSNT_M2C_L	U13
G3	FMC_CLK1_M2C_N	V9	H4	FMC_CLK0_M2C_P	C10
G6	FMC_LA00_CC_P	D9	H5	FMC_CLK0_M2C_N	A10
G7	FMC_LA00_CC_N	C9	H7	FMC_LA02_P	C15
G9	FMC_LA03_P	C13	H8	FMC_LA02_N	A15
G10	FMC_LA03_N	A13	H10	FMC_LA04_P	B16
G12	FMC_LA08_P	F11	H11	FMC_LA04_N	A16

Table C-1: VITA 57.1 FMC LPC Connections (Cont'd)

J1 FMC LPC Pin	Schematic Netname	U1 FPGA Pin	J1 FMC LPC Pin	Schematic Netname	U1 FPGA Pin
G13	FMC_LA08_N	E11	H13	FMC_LA07_P	E7
G15	FMC_LA12_P	D6	H14	FMC_LA07_N	E8
G16	FMC_LA12_N	C6	H16	FMC_LA11_P	B12
G18	FMC_LA16_P	C7	H17	FMC_LA11_N	A12
G19	FMC_LA16_N	A7	H19	FMC_LA15_P	G9
G21	FMC_LA20_P	N7	H20	FMC_LA15_N	F9
G22	FMC_LA20_N	P8	H22	FMC_LA19_P	N6
G24	FMC_LA22_P	R7	H23	FMC_LA19_N	P7
G25	FMC_LA22_N	T7	H25	FMC_LA21_P	T4
G27	FMC_LA25_P	M11	H26	FMC_LA21_N	V4
G28	FMC_LA25_N	N11	H28	FMC_LA24_P	U8
G30	FMC_LA29_P	M8	H29	FMC_LA24_N	V8
G31	FMC_LA29_N	N8	H31	FMC_LA28_P	U11
G33	FMC_LA31_P	T6	H32	FMC_LA28_N	V11
G34	FMC_LA31_N	V6	H34	FMC_LA30_P	T12
G36	FMC_LA33_P	M10	H35	FMC_LA30_N	V12
G37	FMC_LA33_N	N9	H37	FMC_LA32_P	U15
			H38	FMC_LA32_N	V15

SP601 Master UCF

The UCF template is provided for designs that target the SP601. Net names provided in the constraints below correlate with net names on the SP601 rev. C schematic. On identifying the appropriate pins, the net names below should be replaced with net names in the user RTL. See the [Constraints Guide](#) for more information.

NET "CPU_RESET"	LOC = "N4";
NET "DDR2_A0"	LOC = "J7";
NET "DDR2_A1"	LOC = "J6";
NET "DDR2_A2"	LOC = "H5";
NET "DDR2_A3"	LOC = "L7";
NET "DDR2_A4"	LOC = "F3";
NET "DDR2_A5"	LOC = "H4";
NET "DDR2_A6"	LOC = "H3";
NET "DDR2_A7"	LOC = "H6";
NET "DDR2_A8"	LOC = "D2";
NET "DDR2_A9"	LOC = "D1";
NET "DDR2_A10"	LOC = "F4";
NET "DDR2_A11"	LOC = "D3";
NET "DDR2_A12"	LOC = "G6";
NET "DDR2_BA0"	LOC = "F2";
NET "DDR2_BA1"	LOC = "F1";
NET "DDR2_BA2"	LOC = "E1";
NET "DDR2_CAS_B"	LOC = "K5";
NET "DDR2_CKE"	LOC = "H7";
NET "DDR2_CLK_N"	LOC = "G1";
NET "DDR2_CLK_P"	LOC = "G3";
NET "DDR2_DQ0"	LOC = "L2";
NET "DDR2_DQ1"	LOC = "L1";
NET "DDR2_DQ2"	LOC = "K2";
NET "DDR2_DQ3"	LOC = "K1";
NET "DDR2_DQ4"	LOC = "H2";
NET "DDR2_DQ5"	LOC = "H1";
NET "DDR2_DQ6"	LOC = "J3";
NET "DDR2_DQ7"	LOC = "J1";
NET "DDR2_DQ8"	LOC = "M3";
NET "DDR2_DQ9"	LOC = "M1";
NET "DDR2_DQ10"	LOC = "N2";
NET "DDR2_DQ11"	LOC = "N1";
NET "DDR2_DQ12"	LOC = "T2";
NET "DDR2_DQ13"	LOC = "T1";
NET "DDR2_DQ14"	LOC = "U2";
NET "DDR2_DQ15"	LOC = "U1";
NET "DDR2_LDM"	LOC = "K3";
NET "DDR2_LDQS_N"	LOC = "L3";

```

NET "DDR2_LDQS_P"          LOC = "L4";
NET "DDR2_ODT"            LOC = "K6";
NET "DDR2_RAS_B"         LOC = "L5";
NET "DDR2_UDM"           LOC = "K4";
NET "DDR2_UDQS_N"        LOC = "P1";
NET "DDR2_UDQS_P"        LOC = "P2";
NET "DDR2_WE_B"          LOC = "E3";
NET "FLASH_A0"           LOC = "K18";
NET "FLASH_A1"           LOC = "K17";
NET "FLASH_A2"           LOC = "J18";
NET "FLASH_A3"           LOC = "J16";
NET "FLASH_A4"           LOC = "G18";
NET "FLASH_A5"           LOC = "G16";
NET "FLASH_A6"           LOC = "H16";
NET "FLASH_A7"           LOC = "H15";
NET "FLASH_A8"           LOC = "H14";
NET "FLASH_A9"           LOC = "H13";
NET "FLASH_A10"          LOC = "F18";
NET "FLASH_A11"          LOC = "F17";
NET "FLASH_A12"          LOC = "K13";
NET "FLASH_A13"          LOC = "K12";
NET "FLASH_A14"          LOC = "E18";
NET "FLASH_A15"          LOC = "E16";
NET "FLASH_A16"          LOC = "G13";
NET "FLASH_A17"          LOC = "H12";
NET "FLASH_A18"          LOC = "D18";
NET "FLASH_A19"          LOC = "D17";
NET "FLASH_A20"          LOC = "G14";
NET "FLASH_A21"          LOC = "F14";
NET "FLASH_A22"          LOC = "C18";
NET "FLASH_A23"          LOC = "C17";
NET "FLASH_A24"          LOC = "F16";
NET "FLASH_CE_B"         LOC = "L17";
NET "FLASH_D3"           LOC = "U5";
NET "FLASH_D4"           LOC = "V5";
NET "FLASH_D5"           LOC = "R3";
NET "FLASH_D6"           LOC = "T3";
NET "FLASH_D7"           LOC = "R5";
NET "FLASH_OE_B"         LOC = "L18";
NET "FLASH_WE_B"         LOC = "M16";
NET "FMC_CLK0_M2C_N"     LOC = "A10";
NET "FMC_CLK0_M2C_P"     LOC = "C10";
NET "FMC_CLK1_M2C_N"     LOC = "V9";
NET "FMC_CLK1_M2C_P"     LOC = "T9";
NET "FMC_LA00_CC_N"      LOC = "C9";
NET "FMC_LA00_CC_P"      LOC = "D9";
NET "FMC_LA01_CC_N"      LOC = "C11";
NET "FMC_LA01_CC_P"      LOC = "D11";
NET "FMC_LA02_N"         LOC = "A15";
NET "FMC_LA02_P"         LOC = "C15";
NET "FMC_LA03_N"         LOC = "A13";
NET "FMC_LA03_P"         LOC = "C13";
NET "FMC_LA04_N"         LOC = "A16";
NET "FMC_LA04_P"         LOC = "B16";
NET "FMC_LA05_N"         LOC = "A14";
NET "FMC_LA05_P"         LOC = "B14";
NET "FMC_LA06_N"         LOC = "C12";
NET "FMC_LA06_P"         LOC = "D12";
NET "FMC_LA07_N"         LOC = "E8";

```

```

NET "FMC_LA07_P" LOC = "E7";
NET "FMC_LA08_N" LOC = "E11";
NET "FMC_LA08_P" LOC = "F11";
NET "FMC_LA09_N" LOC = "F10";
NET "FMC_LA09_P" LOC = "G11";
NET "FMC_LA10_N" LOC = "C8";
NET "FMC_LA10_P" LOC = "D8";
NET "FMC_LA11_N" LOC = "A12";
NET "FMC_LA11_P" LOC = "B12";
NET "FMC_LA12_N" LOC = "C6";
NET "FMC_LA12_P" LOC = "D6";
NET "FMC_LA13_N" LOC = "A11";
NET "FMC_LA13_P" LOC = "B11";
NET "FMC_LA14_N" LOC = "A2";
NET "FMC_LA14_P" LOC = "B2";
NET "FMC_LA15_N" LOC = "F9";
NET "FMC_LA15_P" LOC = "G9";
NET "FMC_LA16_N" LOC = "A7";
NET "FMC_LA16_P" LOC = "C7";
NET "FMC_LA17_CC_N" LOC = "T8";
NET "FMC_LA17_CC_P" LOC = "R8";
NET "FMC_LA18_CC_N" LOC = "T10";
NET "FMC_LA18_CC_P" LOC = "R10";
NET "FMC_LA19_N" LOC = "P7";
NET "FMC_LA19_P" LOC = "N6";
NET "FMC_LA20_N" LOC = "P8";
NET "FMC_LA20_P" LOC = "N7";
NET "FMC_LA21_N" LOC = "V4";
NET "FMC_LA21_P" LOC = "T4";
NET "FMC_LA22_N" LOC = "T7";
NET "FMC_LA22_P" LOC = "R7";
NET "FMC_LA23_N" LOC = "P6";
NET "FMC_LA23_P" LOC = "N5";
NET "FMC_LA24_N" LOC = "V8";
NET "FMC_LA24_P" LOC = "U8";
NET "FMC_LA25_N" LOC = "N11";
NET "FMC_LA25_P" LOC = "M11";
NET "FMC_LA26_N" LOC = "V7";
NET "FMC_LA26_P" LOC = "U7";
NET "FMC_LA27_N" LOC = "T11";
NET "FMC_LA27_P" LOC = "R11";
NET "FMC_LA28_N" LOC = "V11";
NET "FMC_LA28_P" LOC = "U11";
NET "FMC_LA29_N" LOC = "N8";
NET "FMC_LA29_P" LOC = "M8";
NET "FMC_LA30_N" LOC = "V12";
NET "FMC_LA30_P" LOC = "T12";
NET "FMC_LA31_N" LOC = "V6";
NET "FMC_LA31_P" LOC = "T6";
NET "FMC_LA32_N" LOC = "V15";
NET "FMC_LA32_P" LOC = "U15";
NET "FMC_LA33_N" LOC = "N9";
NET "FMC_LA33_P" LOC = "M10";
NET "FMC_PRSNT_M2C_L" LOC = "U13";
NET "FMC_PWR_GOOD_FLASH_RST_B" LOC = "B3";
NET "FPGA_AWAKE" LOC = "P15";
NET "FPGA_CCLK" LOC = "R15";
NET "FPGA_CMP_CLK" LOC = "U16";
NET "FPGA_CMP_CS_B" LOC = "P13";

```

```

NET "FPGA_CMP_MOSI"                LOC = "V16";
NET "FPGA_D0_DIN_MISO_MISO1"       LOC = "R13";
NET "FPGA_D1_MISO2"                LOC = "T14";
NET "FPGA_D2_MISO3"                LOC = "V14";
NET "FPGA_DONE"                    LOC = "V17";
NET "FPGA_HSWAPEN"                 LOC = "D4";
NET "FPGA_INIT_B"                  LOC = "U3";
NET "FPGA_M0_CMP_MISO"              LOC = "T15";
NET "FPGA_M1"                       LOC = "N12";
NET "FPGA_MOSI_CSI_B_MISO0"         LOC = "T13";
NET "FPGA_ONCHIP_TERM1"             LOC = "L6";
NET "FPGA_ONCHIP_TERM2"             LOC = "C2";
NET "FPGA_PROG_B"                   LOC = "V2";
NET "FPGA_SUSPEND"                  LOC = "R16";
NET "FPGA_TCK_BUF"                  LOC = "A17";
NET "FPGA_TDI_BUF"                  LOC = "D15";
NET "FPGA_TDO"                      LOC = "D16";
NET "FPGA_TMS_BUF"                  LOC = "B18";
NET "FPGA_VTEMP"                    LOC = "P3";
NET "GPIO_BUTTON0"                  LOC = "P4";
NET "GPIO_BUTTON1"                  LOC = "F6";
NET "GPIO_BUTTON2"                  LOC = "E4";
NET "GPIO_BUTTON3"                  LOC = "F5";
NET "GPIO_HDR0"                      LOC = "N17";
NET "GPIO_HDR1"                      LOC = "M18";
NET "GPIO_HDR2"                      LOC = "A3";
NET "GPIO_HDR3"                      LOC = "L15";
NET "GPIO_HDR4"                      LOC = "F15";
NET "GPIO_HDR5"                      LOC = "B4";
NET "GPIO_HDR6"                      LOC = "F13";
NET "GPIO_HDR7"                      LOC = "P12";
NET "GPIO_LED_0"                     LOC = "E13";
NET "GPIO_LED_1"                     LOC = "C14";
NET "GPIO_LED_2"                     LOC = "C4";
NET "GPIO_LED_3"                     LOC = "A4";
NET "GPIO_SWITCH_0"                  LOC = "D14";
NET "GPIO_SWITCH_1"                  LOC = "E12";
NET "GPIO_SWITCH_2"                  LOC = "F12";
NET "GPIO_SWITCH_3"                  LOC = "V13";
NET "IIC_SCL_MAIN"                   LOC = "P11";
NET "IIC_SDA_MAIN"                   LOC = "N10";
NET "PHY_COL"                         LOC = "L14";
NET "PHY_CRS"                         LOC = "M13";
NET "PHY_INT"                         LOC = "J13";
NET "PHY_MDC"                         LOC = "N14";
NET "PHY_MDIO"                       LOC = "P16";
NET "PHY_RESET"                       LOC = "L13";
NET "PHY_RXCLK"                       LOC = "L16";
NET "PHY_RXCTL_RXDV"                 LOC = "N18";
NET "PHY_RXD0"                        LOC = "M14";
NET "PHY_RXD1"                        LOC = "U18";
NET "PHY_RXD2"                        LOC = "U17";
NET "PHY_RXD3"                        LOC = "T18";
NET "PHY_RXD4"                        LOC = "T17";
NET "PHY_RXD5"                        LOC = "N16";
NET "PHY_RXD6"                        LOC = "N15";
NET "PHY_RXD7"                        LOC = "P18";
NET "PHY_RXER"                        LOC = "P17";
NET "PHY_TXCLK"                       LOC = "B9";

```

```
NET "PHY_TXCTL_TXEN"          LOC = "B8";
NET "PHY_TXC_GTXCLK"         LOC = "A9";
NET "PHY_TXD0"               LOC = "F8";
NET "PHY_TXD1"               LOC = "G8";
NET "PHY_TXD2"               LOC = "A6";
NET "PHY_TXD3"               LOC = "B6";
NET "PHY_TXD4"               LOC = "E6";
NET "PHY_TXD5"               LOC = "F7";
NET "PHY_TXD6"               LOC = "A5";
NET "PHY_TXD7"               LOC = "C5";
NET "PHY_TXER"               LOC = "A8";
NET "SMACLK_N"               LOC = "H18";
NET "SMACLK_P"               LOC = "H17";
NET "SPI_CS_B"               LOC = "V3";
NET "SYSCLK_N"               LOC = "K16";
NET "SYSCLK_P"               LOC = "K15";
NET "USB_1_CTS"              LOC = "U10";
NET "USB_1_RTS"              LOC = "T5";
NET "USB_1_RX"               LOC = "L12";
NET "USB_1_TX"               LOC = "K14";
NET "USER_CLOCK"             LOC = "V10";
```