

Module SERVO 2

SKU:M014-B



Description

SERVO 2 is an updated servo driver module in the M5Stack stackable module series. It uses a PCA9685 16 channel PWM controller to control 16 channel servos at the same time. The power input is 6-12V DC and two SY8368AQQC chips are used for voltage reduction.

The maximum total power output of dual channel is 35W ($5V / 3.5A * 2$), and the maximum output power of single channel is 25W ($5V / 5A$). When the battery base is used for power supply, the maximum output power is 5V / 2A. The module communicates with the host directly through I2C (the default address is 0x40) however the I2C address can be changed (0x40 - 0x47) through the dial switch. This also means that multiple Servo 2 modules can be stacked and used simultaneously. There is a power switch on the board to control the power supply of Servo 2.

The module must use the external power supply of DC interface when driving the servo. When using the AXP192 power management chip's main control (such as CORE2), the M-BUS power mode needs to be configured as input when the program is initialized.

Product Features

- 16x actuator drive channel
- 2X power indicator
- I2C address adjustable
- External DC power supply input: 6-12V
- DC connector type: XT60

Include

- 1x Servo2 Module
- 1x XT60 power cable(11.5cm)

Applications

- Humanoid robot
- Bionic multi joint robot
- 3-axis steering gear pan tilt

Specification

Resources	Parameter
Net weight	28g
Gross weight	60g
Product Size	54.2*54.2*13.2mm
Package Size	95*65*25mm

EasyLoader

EasyLoader is a concise and fast program writer, which has a built-in case program related to the product. It can be burned to the main control by simple steps to perform a series of function verification. Please install the corresponding driver according to the device type. M5Core host [Please click here to view the CP210X driver installation tutorial](#), M5StickC/V/T/ATOM series can be used without driver)

2, Select COM



1, Downloads

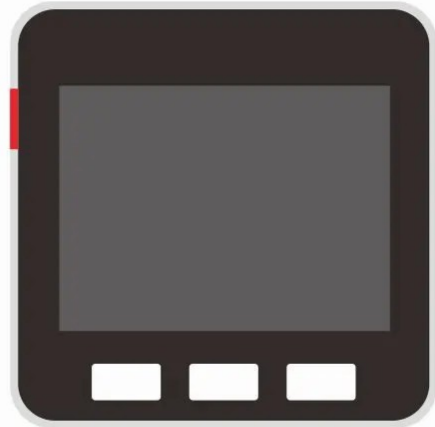
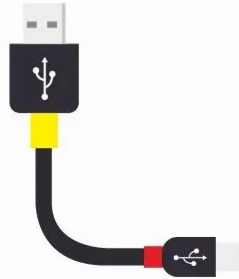

Core \ M5StickC \ M5StickV...

3, Burn Firmware

Windows MacOS

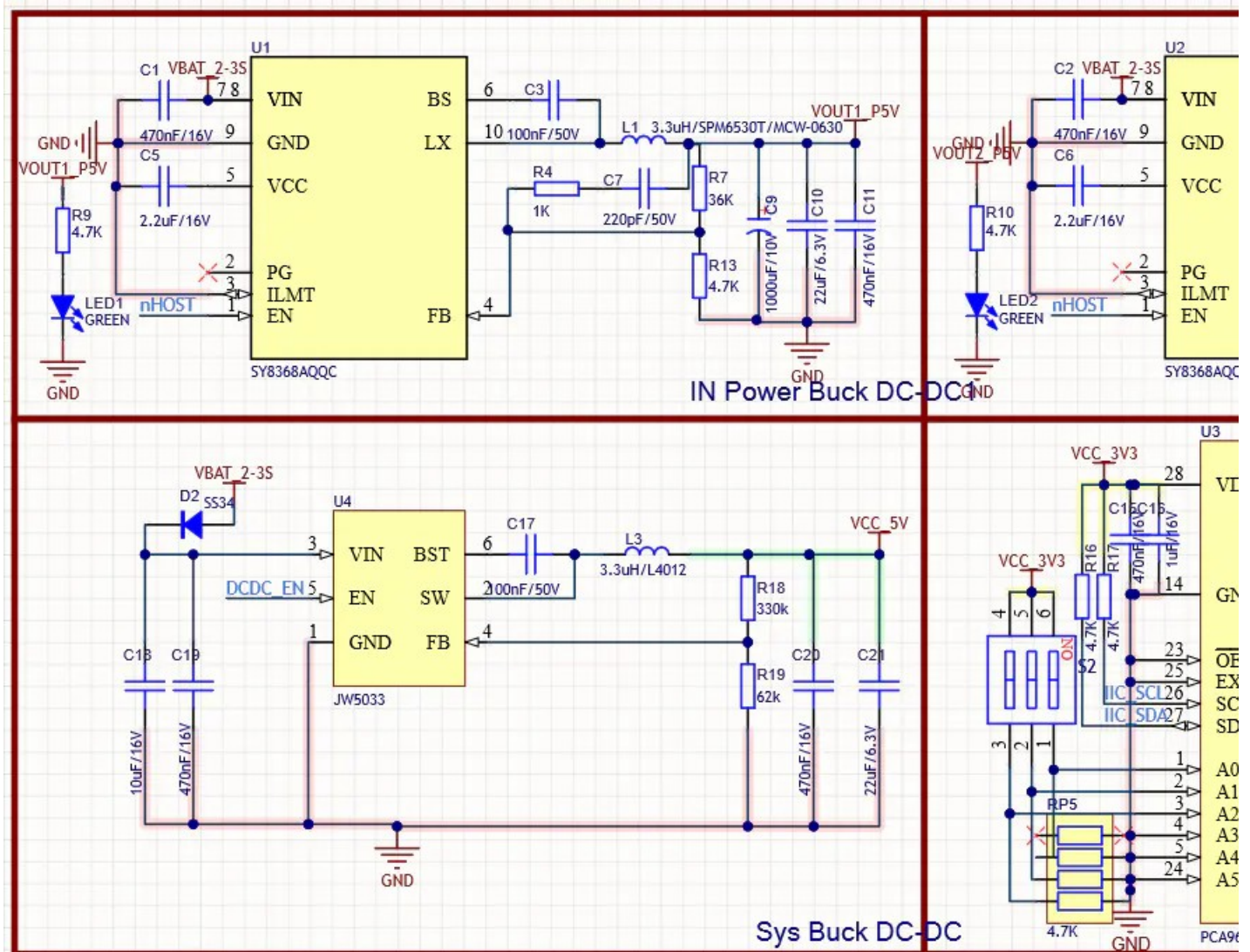

Related Link

- [PCA9685](#)

Example

1. Arduino IDE

To get the complete code, please click [here](#)

2. UIFlow

- [Click here to download the UIFlow example](#)

The image shows a software development environment for a microcontroller project named "SERVO2".

- UI Preview:** A smartphone-like interface displays "Servo2" at the top, followed by "Index 0 Degree : label2". Below the text are three square buttons.
- Component Library:** A sidebar on the left lists various components under "Units":
 - Event
 - UI
 - Hardwares
 - Units
 - Modules
 - LoRaWAN
 - STEPMOTOR
 - SERVO
 - SERVO2** (highlighted)
 - Bala
 - Bala Motor
 - DC Motor
 - PM2.5
- Block-based Program:** The main workspace contains the following code:
 - Setup:** A block to "set a to 0".
 - Button A - wasPressed:** An event-driven block containing:
 - if** block: "a" == 1
 - do** block:
 - Set 0 servo position 0
 - set a to 0
 - Label label2 show "0"
 - else** block:
 - Set 0 servo position 90
 - set a to 1
 - Label label2 show "90"
 - Button B - wasPressed:** A block containing "Set 0 servo release".